



# INSTALLATION, MAINTENANCE & TROUBLESHOOTING GUIDE



## TABLE OF CONTENTS

### Installation

Storage .....	1
Handling.....	1
Installation .....	2
Stringing the Belt .....	5
Tensioning .....	5
Training the Belt .....	7
Factors Affecting the Training of a Belt.....	8
Sequence of Training Operations.....	13
Cleaning .....	15
Loading.....	17
Curved Chutes .....	20
Pulley Lagging .....	20
Types of Lagging.....	21
Transition Distances .....	23
Turnovers.....	24

### Troubleshooting

Problems, Causes and Solutions .....	25
--------------------------------------	----

### Maintenance

Conveyor Belt Repairs.....	32
----------------------------	----

<b>Shipping</b> .....	39
-----------------------	----

<b>Quick-Check</b> .....	40
--------------------------	----

<b>Belt Roll Diameters</b> .....	41
----------------------------------	----

<b>Terms and Conditions</b> .....	43
-----------------------------------	----

## STORAGE

The methods of storing and handling conveyor belting and the procedures for tensioning it before making the final splice are just as important as actually making the splice. Protect your conveyor belt investment with proper storage. Belts should always be stored upright in the factory package until used in a cool, dry building and in an area free from sunlight. Store the belt roll suspended on a tube, bar or support stand. Under no conditions should rolls of belt, especially raw edge or used, be laid flat on its side. Storing the belt flat on the ground, where moisture can penetrate exposed fabric, or storing the belt roll with weight on one edge, may stretch the belt. This can cause belt camber or a bowing in the belt, resulting in serious belt mistracking.

During extended storage, the belt roll should be covered with a tarp or dark plastic. Exposure to sunlight, rain and ozone can have detrimental effects on the rubber covers. The cover should remain in place for the entire storage time. Ideally, the belt should be rotated 90 degrees approximately every 90 days. Rotation should be performed in the same direction used to wind up the belt. Rotating in the opposite direction could cause the roll to loosen or telescope.

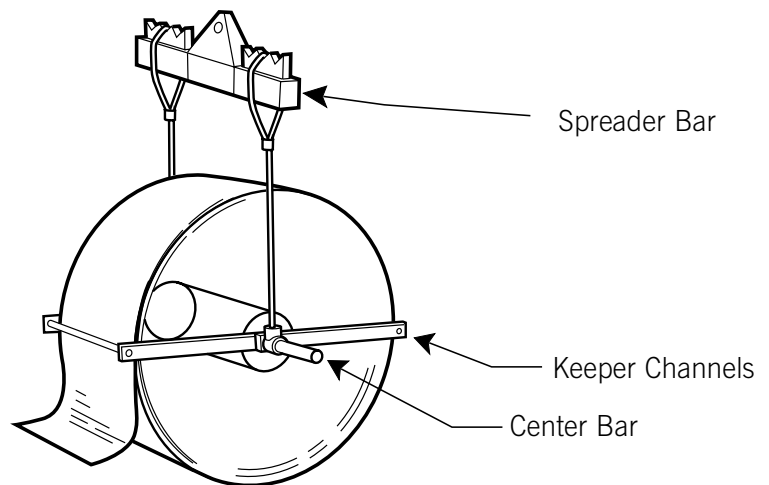
It is important to make sure the belt is not exposed to extreme temperatures during storage. Ideal temperature for storing a belt is between 50° F and 70° F. Temperatures outside of this range for an extended period of time can have detrimental effects on the rubber compounds.

As the length of time stored increases, and as the size of the roll of belting increases, so does the importance of the following correct storage procedures. Following these procedures will increase the life of the belt once it is installed on the system.

## HANDLING THE ROLL

Conveyor belting is customarily packaged in cylindrical reels, or rolls on a core with the carrying cover side facing out. If rolling is necessary, it should occur in a direction such that the end of the roll on the outside wrap travels in the direction from which it is wound up. Rolling in the opposite direction tends to loosen and telescope the belt.

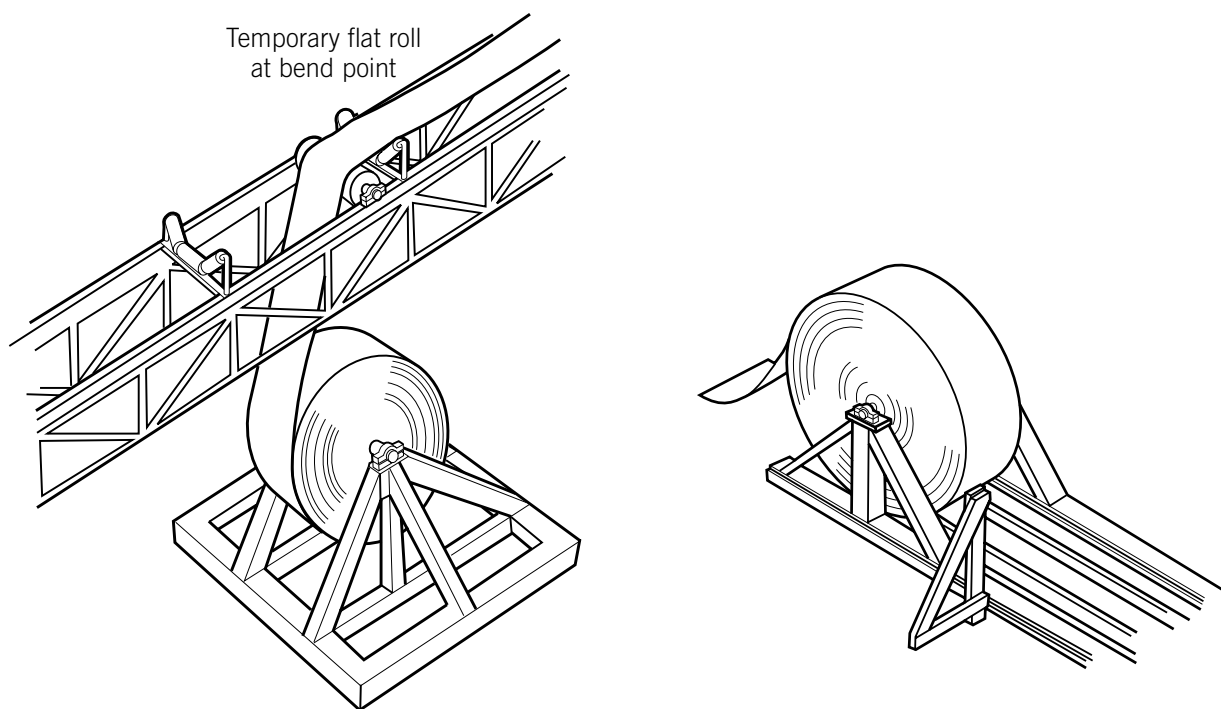
Reels or rolls should never be dropped from a freight car, truck, or other means of conveyance, since their weight will break the packaging and may damage the belt. Reels or rolls should always be rolled, or provision should be made for hoisting them. For hoisting, a square lifting bar of the correct size should be placed through the hole in the center of the core. A spreader bar should be utilized to prevent the chains or slings from damaging the edges of the conveyor belt. Slings or chains of the correct size for the weight of the roll should be used (Fig. 1).



**Fig. 1**

## INSTALLATION

The relative position of the top and bottom covers or surfaces of the belt should be considered when positioning the roll for threading. Once the roll of belting has been transported to the point of installation, it should be mounted on a suitable shaft for unrolling and threading onto the conveyor. Conveyor belting is normally rolled at the factory with the carrying side out. Consequently, in mounting the roll, the belt must lead off the top of the roll if it is being pulled onto the troughing or carrying idlers, but off the bottom of the roll if it is being pulled onto the return idlers. When pulling the belt onto the conveyor, the roll will turn opposite the direction indicated by the arrows on the crate. Fig. 2 illustrates a suitable method of mounting, as well as leading off the top of the roll for pulling onto the troughing idlers.



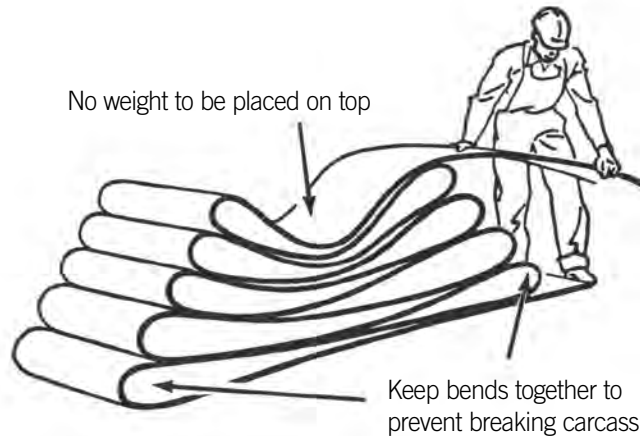
**Fig. 2**

Note: Temporary flat roll at bend point, as roll is pulled onto troughing idlers.

# INSTALLATION, MAINTENANCE & TROUBLESHOOTING GUIDE

## INSTALLATION

In some cases, such as in mines where headroom does not permit maneuvering a roll, the belt may have to be pulled off the roll and reefed (Fig. 3). Extreme care should be exercised to see that the loops have large bends to avoid kinking or placing undue strain on the belt, and no weight should ever be placed on the belt when it is in this position. Ideally, supports should be placed at each end where the bends occur.



**Fig. 3**

Reefing the Belt

A third method of handling the roll, where headroom for mounting on a horizontal shaft is lacking, is mounting on a turntable with a vertical spindle. The belt must make a 90-degree twist as it comes off the turntable. This method is sometimes used underground, with the turntable mounted on wheels or skids for transporting the roll of belt as it lies on its side, as well as for unrolling it at the final location.

If the belt is for replacement, the new roll can be set up as previously indicated. The old belt is clamped off and cut, and the new belt is spliced to the leading end of the old belt by using approximately one-half the usual number of plate-type fasteners. The trailing end of the old belt is hooked to a truck, tractor, mine locomotive, or other means of providing traction. The conveyor drive motor is used to pull on the new belt while the towing device drags the old belt away and at the same time provides sufficient slack side tension for the conveyor drive pulley. In all cases, care should be exercised to ensure the carrying side of the conveyor is placed upward if pulling onto the top run, or downward if pulling onto the return run.

For a new conveyor installation having little or no slope, a rope or cable should be attached to a clamp at the belt end. In clamping to the end of the belt for pulling it on the conveyor, it is not sufficient to cut a hole through the belt or ears into its corners for tying on a rope. A clamp should be made to distribute the pull applied to the end across its full width. Since the clamp must pass through places of low clearance, it usually is made of two pieces of 1/4-inch to 1/2-inch plate approximately equal to the belt width and 4 inches long. One piece is placed against each surface of the belt at the end, and bolts are placed through both plates at about 6-inch intervals and 2 inches back from the belt end. The rope is then attached to this clamp with a shackle or by welding an eye to one of the plates. The belt roll has been handled as previously described. The rope or cable is then threaded over the conveyor and attached to a towing device to pull the belt onto the conveyor.

# INSTALLATION, MAINTENANCE & TROUBLESHOOTING GUIDE

## INSTALLATION

For installations with a relatively high degree of slope (12 degrees or more), the method of handling is slightly different. The roll of belt is set up as previously described. It is often found most convenient to place it at or near the head pulley, since this generally is the most accessible. Assuming the conveyor is sufficiently long to require more than one splice, the conveyor side and the return sides are threaded on separately. Care must be taken to see that conveyor side or heavier cover is up on the carrying side and down on the return run.

As the belt is fed on, the tension at the roll tends to build up due to the weight of the belt on the slope. For this reason, some method of braking is required. Customary practice is to use a belt clamp, mounted on the conveyor structure, through which the belt is threaded. Where the slope is very long, additional clamps should be spaced approximately 1000 feet apart. Where more than one clamp is used, workers are stationed at each clamp to loosen and tighten the clamps as the belt is fed onto the conveyor. Care must be exercised that the belt does not run away. As a roll runs out, another is spliced on and then fed onto the conveyor.

If the conveyor side and the return side have been fed on separately, the final splice is best made at the bottom of the slope where the ends of the belt meet, since a much lower splicing tension will serve at this point. Making the final splice at the top of the slope is entirely possible but requires proper splicing tension.

When pulling the belt onto the system, station personnel at key points along the conveyor to help avoid the belt from hanging up on the structure resulting in belt damage. Pull the belt ends until they overlap the required splicing length.

To prevent the belt roll from over-running at the let-off, a braking device is often needed (Fig. 4).

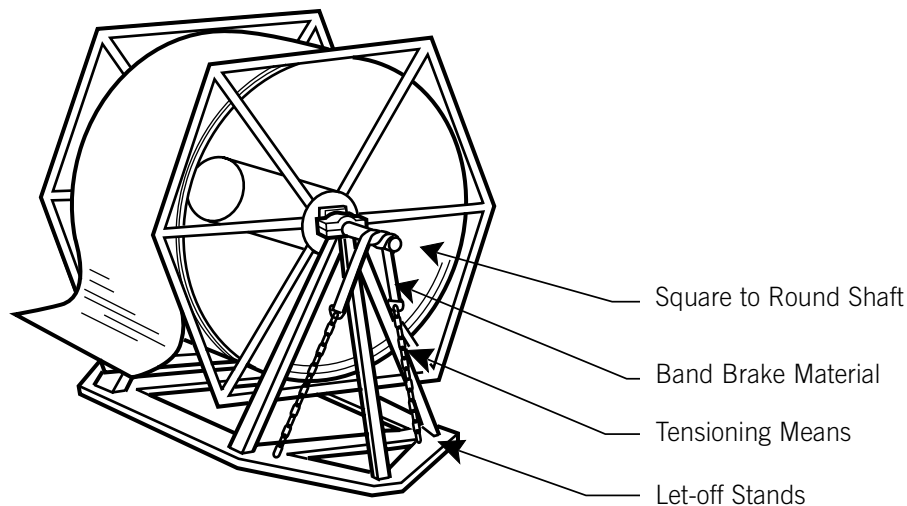


Fig. 4

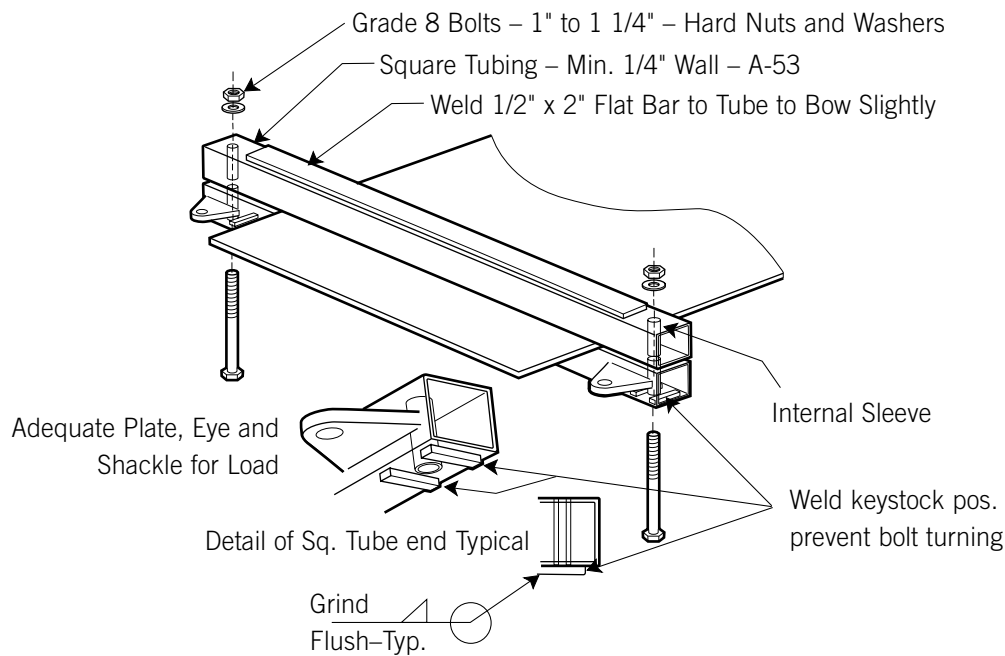
## STRINGING THE BELT

Textile belts such as Pylon Plus®, Pylon®, Raider®, Pathfinder®, etc. that have been slit from a full-width slab at the factory should be spliced with the factory-cut edges on the same side of the conveyor (Goodyear Engineered Products identifies these edges with white paint applied at the factory after slitting). The factory-edge side of slit belts will be identified by painting "Factory Edge" on that side and a solid white 3" strip will be painted across the full diameter of the same edge.

To minimize side travel on steel cord belt rolls, it is recommended that rolls be strung onto the conveyor in the exact sequence they were manufactured.

## TENSIONING

Once the belt has been pulled onto the conveyor system, it must be tensioned prior to splicing to facilitate correct positioning of the take-up and to eliminate sag. The tensioning operation takes place at the location where the last splice will be made. After final tensioning, clamps are placed on each end of the belt. These are made of steel and have a clamping surface as indicated in Figure 5.



**Fig. 5**

Tension Clamp for Splicing

Tension is applied by means of a power device, which is used to pretension the belt before "clamping off."

When tension measuring load cells or scales are used, they are rigged to measure the pull on the take-up pulley. The belt is pulled until the load cells or scales register a tension equal to or slightly greater than the recommended take-up force. Make allowance for an amount of belt necessary to correctly position the counterweight from this point.

# INSTALLATION, MAINTENANCE & TROUBLESHOOTING GUIDE

## INSTALLATION

Certain basic statements and recommendations can be made about tensioning for splicing:

- Belts which are tensioned by pulling in only one direction require more splicing tension than those pulled in both directions.
- Slope belts spliced at the top of the slope require more splicing tension than those spliced at the bottom.
- Slope belts with an anti-rollback device that cannot be released must be tensioned by pulling only in the direction of belt travel.
- Check the belt frequently during tensioning to ensure that the belt is free and not binding at any place.
- During the final tensioning pull, be sure the ends of the belt are lined up properly.

Conveyor installations having limited take-up travel should be spliced to a tension based on the loaded running tension. This tension should be specified by Goodyear Engineered Products and measured by suitable load cells or dynamometers. Where it is practical, fabric belts should be run for several weeks with mechanical fasteners before making the final vulcanized splice.

Obtaining the required tension depends heavily on the experience of the individual making the splice. It is possible for a gravity type take-up to severely damage the conveyor structure if it is positioned too close to the forward or upward stop. Too much tension applied to a relatively short belt may thus have a harmful effect on the pulley shafts and bearings as well as the belt.

The belt may be tensioned with a suitable take-up device as follows:

When the counterweight is on: Tie the take-up off 6" to 8" (150mm to 200mm) above the desired running position (Consideration may have to be made for excessive sag). Next, pull the belt until the take-up starts to lift and the tie-off ropes become slack. Make the final splice, allowing a minimum of belt slack.

When the counterweight is not on: Splicing without the counterweight installed is undesirable; however, the following procedure should be employed if necessary: Use suitable belt clamps to hold the take-up pulley 6" to 8" (150mm to 200mm) above the desired running position (Consideration may have to be made for excessive sag). Pull the belt to its running tension, which can only be estimated in this situation. Judgment in estimating this tension will improve with the experience of the splicer.

Tables 1-1 and 1-2 show the recommended take-up travel and initial take-up position respectively.

**TABLE 1-1  
RECOMMENDED MINIMUM TAKE-UP TRAVEL  
IN PERCENT OF CENTER DISTANCE\***

TYPE OF TAKE-UP AND CARCASS MATERIAL [WARP]	PERCENT OF RATED TENSION		
	100%	75%	50% or LESS
<b>MANUAL TAKE-UP**</b>			
NYLON	4.00%	3.00%	2.00%
POLYESTER	2.50%	2.00%	1.50%
ARAMID	2.00%	1.50%	1.00%
FIBERGLASS	1.00%	0.75%	0.50%
<b>AUTOMATIC TAKE-UP</b>			
NYLON	3.00%	2.50%	1.50%
POLYESTER	1.70%	1.25%	0.75%
ARAMID	1.50%	1.00%	0.75%
FIBERGLASS	0.50%	0.40%	0.25%
STEEL	0.30%	1.23%	0.15%

\*For [1] belts installed at average empty running tension [2] take-up position per Table 1-2, and [3] Drive location at or near the high tension end of the conveyor.

\*\*Only short endless feeder belts and the like would normally be vulcanized on conveyors with a manual take-up.



**TABLE 1-2**  
**RECOMMENDED INITIAL TAKE-UP POSITION+**

CARCASS MATERIAL [WARP]	PERCENT AVAILABLE FOR LENGTH INCREASE	PERCENT AVAILABLE FOR LENGTH DECREASE
STEEL	25%	75%
NYLON, POLYESTER, ARAMID, FIBERGLASS	90%	10%

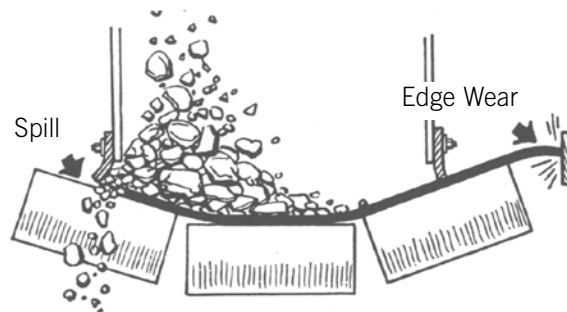
+Take-up conditions and travel amounts as shown in Table 1-1.

## TRAINING THE BELT

Training the belt is a process of adjusting idlers, pulleys, and loading conditions in a manner that will correct any tendency of the belt to run other than centrally. The following causes of common belt performance are considered axiomatic.

When all portions of a belt run off through a part of the conveyor length, the cause is probably in the alignment or leveling of the conveyor structures, idlers, or pulleys in that region. If one or more portions of the belt run off at all points along the conveyor, the cause is more likely in the belt itself, in the joints of the belt, or in the loading of the belt. When the belt is loaded off-center, the center of gravity of the load tends to find the center of the troughing idlers, thus leading the belt off on its lightly loaded edge (Fig. 6).

These basic rules can be used to diagnose belt running ills. Combinations of these rules sometimes produce cases that do not appear clear-cut as to cause, but if there are a sufficient number of belt revolutions, the running pattern will become clear and the cause disclosed. The usual cases when a running pattern does not emerge are those of erratic running, which may be found with an unloaded belt that does not trough well, or a loaded belt that is not receiving its load uniformly centered.



**Fig. 6**  
Effects of Off-Center Loading

## **FACTORS AFFECTING THE TRAINING OF A BELT**

### **Pulleys and Snubs**

Relatively little steering effect is obtained from the crown of conveyor pulleys. Crowning is most effective when there is a long unsupported span of belting (approximately four times belt width) approaching the pulley. Since this is not possible on the conveyor carrying side, head pulley crowning is relatively ineffective and is not worth the lateral mal-distribution of tension it produces in the belt.

Tail pulleys may have such an unsupported span of belt approaching them and may be crowned with benefit, except when they are at points of high belt tension. The greatest advantage is that the crown, to some degree, assists in centering the belt as it passes beneath the loading point; this is necessary for good loading.

Take-up pulleys are sometimes crowned to take care of any slight misalignment that occurs in the take-up carriage as it shifts position. In general, crowned pulleys should be used sparingly, if at all, on fabric belts. With steel cord belts, all pulleys must be flat.

All pulleys should be level and should have their axis at 90 degrees to the intended path of the belt. They should be kept that way and not shifted as a means of training, except that snub pulleys can have their axis shifted when other means of training have provided insufficient correction. Pulleys with their axis at other than 90 degrees to the belt path will lead the belt in the direction of the edge of the belt that first contacts the misaligned pulley. When pulleys are not level, the belt tends to run to the low side. This is contrary to the old rule-of-thumb statement that a belt runs to the high side of the pulley. When combinations of these two occur, the one having the stronger influence will become evident in the belt performance.

### **Carrying Idlers**

The belt can be trained with the troughing idlers in two ways. Shifting the idler axis with respect to the path of the belt, commonly known as knocking idlers, is effective where the entire belt runs to one side along some portion of the conveyor. The belt can be centered by knocking ahead (in the direction of belt travel) the end of the idler to which the belt runs (Fig. 7). Shifting idlers in this way should be spread over some length of the conveyor preceding the region of the trouble. It will be recognized that a belt might be made to run straight with half the idlers knocked one way and half the other, but this would be at the expense of increased rolling friction between belt and idlers. For this reason, all idlers initially should be squared with the path of the belt and only the minimum shifting of idlers used as a training means. If the belt is overcorrected by shifting idlers, it should be restored by moving back the same idlers, not by shifting additional idlers in the other direction.

Such idler shifting is effective for only one direction of belt travel. If the belt is reversed, a shifted idler, corrective in one direction, is misdirective in the other. Hence, reversing belts should have all idlers squared up and left that way. Any correction required can be provided with self-aligning idlers designed for reversing operation. Not all self-aligners are of this type, for some work in one direction only.

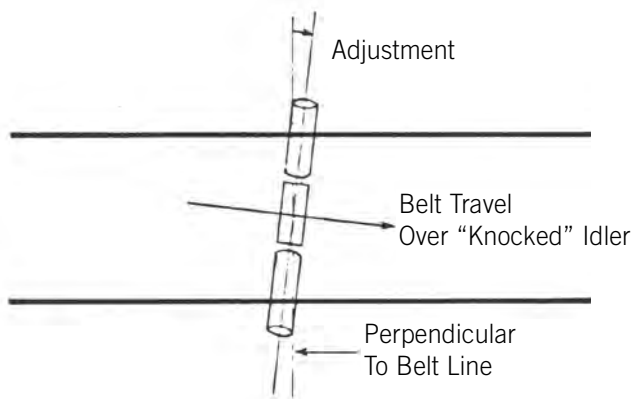
# INSTALLATION, MAINTENANCE & TROUBLESHOOTING GUIDE

## INSTALLATION

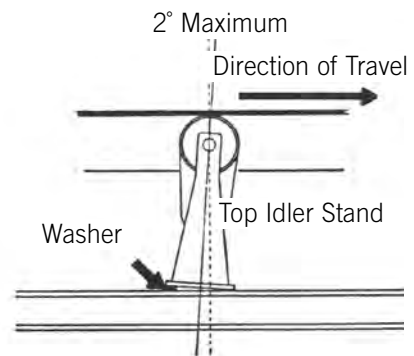
Tilting the troughing idler forward (not over two degrees) in the direction of belt travel produces a self-aligning effect. The idlers can be tilted in this manner by shimming the rear leg of the idler stand. Here again, this method is not satisfactory where belts may be reversing. The tilted troughing idler is shown in Fig. 8.

This method has an advantage over knocking idlers in that it will correct for movement of the belt to either side of the idler; hence, it is useful for training erratic belts. This method has the disadvantage of encouraging accelerated pulley cover wear due to increased friction on the troughing rolls. It should, therefore, be used as sparingly as possible, especially on higher-angle idlers.

Special, self-aligning troughing idlers are available to assist in training the belt (Fig. 9). For a more complete discussion of these idlers, refer to the Goodyear Engineered Products' "Handbook of Conveyor and Elevator Belting."

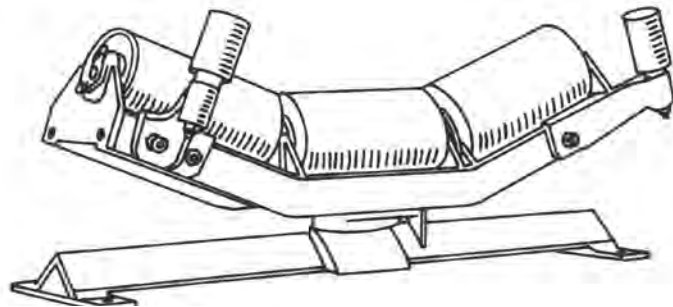


**Fig. 7**



**Fig. 8**

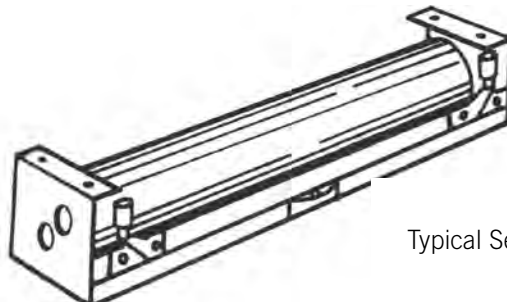
**Fig. 9**  
Typical Self-Aligning Troughing Idler



## Return Idlers

Return idlers, being flat, provide no self-aligning influence as in the tilted troughing idlers. However, by shifting their axis with respect to the path of the belt, the return roll can be used to provide a constant corrective effect in one direction. As in the troughing rolls, the end of the roll toward which the belt is shifting should be moved longitudinally in the direction of return belt travel to provide correction.

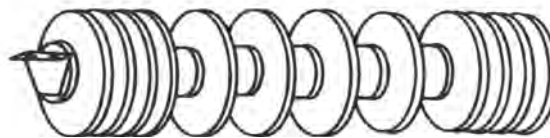
Self-aligning return rolls also should be used. These rolls are pivoted about a central pin. Pivoting of the roll about this pin results from an off-center belt and the idler roll axis thus becomes shifted, with respect to the path of the belt, in a corrective direction (Fig. 10).



**Fig. 10**  
Typical Self-Aligning Return Idler

Some return idlers are made with two rolls forming a 10-degree to 20-degree V-trough, which is effective in helping to train the return run. The V-return idlers are only recommended for fabric belts wider than 54". The most important criteria for belt training is idler contact in the center. If the belt has taken a set on the trough side and V-return idlers are being used, the center of the belt is not able to make contact with the center of the V-return idlers. A hold-down roller on the return side will help in training the belt, as it forces the belt to lay flat on the following idlers.

Rubber-segmented disk return idlers (Fig. 11) are used for cleaning the belt and help in belt training. When one of the discs on the edges falls off, the belt edges tend to get caught, forcing the belt to run one way and become a belt de-trainer. Minimum of 8" of belt contact is recommended for disc return idlers.



**Fig. 11**  
Rubber Disk Return Idler

## Automatic Aligning Devices

Self-aligning conveyor and return idlers have already been described. Center pivoted return idlers are sometimes connected in groups of two or three to operate together and are actuated by an external mechanism that takes its indication from the belt position. They have a very strong influence in centering the return belt as it approaches the tail pulley.

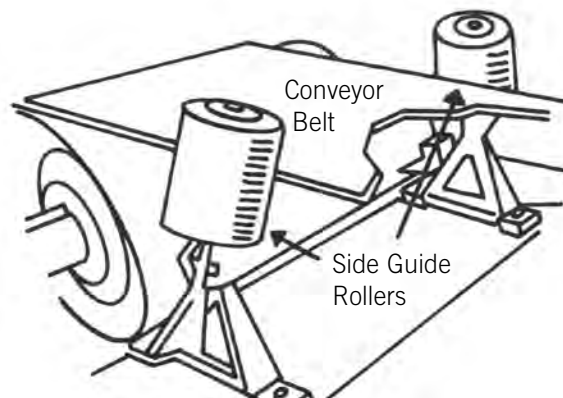
A snub pulley also can be arranged to provide the same strong self-aligning influence; however, in place of a center pivot (as in return rolls), it is usually pivoted at one end of its shaft. The other end is shifted by mechanical, electrical or hydraulic means as indication is received from the belt position.

## Assuring Effectiveness of Training Rolls

Normally, extra pressure is desired on self-aligning idlers, and in some cases, on standard idlers where strong training influence is required. One way to achieve this is to raise such idlers above the line of adjacent idlers. Idlers or bend pulleys on convex curves along the return run have extra pressure due to a component of the belt tension, and are therefore effective training locations. However, carrying side self-aligners should never be located on a convex curve, since their elevated position can promote idler juncture failure.

## Side Guide Rollers

Guides of this type are not recommended for use in making belts run straight. They can be used to assist in training the belt initially to prevent it from running off the pulleys and damaging itself against the structure of the conveyor system. They also can be used to afford the same sort of protection to the belt as an emergency measure, provided they do not touch the belt edge when it is running normally. If they bear on the belt continually, even though free to roll, they tend to wear off the belt edge and eventually cause ply separation along the edge. Side guide rollers should not be located so that they bear against the belt edge once the belt is actually on the pulley. At this point, no edge pressure can move the belt laterally (Fig. 12).



**Fig. 12**

## The Belt Itself

A belt having extreme lateral stiffness, relative to its width, will be more difficult to train due to its lack of contact with the center roll of the carrying idler. Recognition of this fact enables the user to take extra precaution and, if necessary, load the belt during training to improve its steerability. Observation of troughability design limitations will normally avoid this trouble (Fig. 13).

Some new belts may tend to run off to one side, in a certain portion or portions of their length, because of temporary lateral mal-distributions of tension. Operation of the belt under tension corrects this condition in practically all cases. Use of self-aligning idlers will aid in making the correction.



Incorrect Troughing



Correct Troughing

**Fig. 13**

## SEQUENCE OF TRAINING OPERATIONS

Initial installation of conveyor equipment should ensure good alignment of all pulleys, troughing idlers and return idlers; that is, they should be placed at right angles to the direction of belt travel and should be leveled and centered on a straight line. First movement of the belt should be slow and intermittent so that any tendency of the belt to run off can be quickly observed and the belt stopped before damage occurs.

When the conveyor is a long center installation, men should be stationed at frequent intervals to observe the action of the belt. They should be provided with an effective method of communication so they can report their observations and if necessary, stop the belt.

Initial movement of the belt will indicate where corrections of the types described are required. The first corrections must be at points where the belt is in danger of being damaged. Once the belt is clear of all danger points, a sequence of training operations can be followed. Since the training will finally complete a circuit, just as the belt does, there is no point at which training can be started without the possibility of having to make subsequent corrections when returning to the starting point as the circuit is completed. The best procedure appears to be in starting with the return run and working toward the tail pulley. This ensures early centering of the belt on the tail pulley so that it can receive its load centrally, which is highly important.

If the belt is readily troughable so that its running tendencies are not erratic, the training can and should be completed on the empty belt. Should it tend toward stiffness and erratic running, getting some load onto the belt as soon as the return run has been straightened up and the belt is centered on the tail pulley will help hold the top run.

Normally, the belt can be trained properly onto the tail pulley by manipulation of return idlers and with the assistance of self-aligning return rolls. Seldom is any adjustment of snub or tail pulley necessary, but the snub can be used in supplementary training.

Training of the top run, with the belt empty, is usually no problem if the belt is readily troughable. In this case, self-aligners on top are not required, except as insurance in the region approaching the head pulley. There, two self-aligners placed approximately 40 and 80 feet preceding the pulley will help re-center the belt if it is forced off due to some temporary disturbance.

It should not be necessary to use the head pulley for training purposes if it has been aligned properly. Likewise, the snub following the head pulley should not be required as a training means, since it is relatively ineffective in its position following the strong head pulley influence.

The take-up carriage has a strong influence on the running of the belt at that point, and due to its movement as belt length changes, is subject to misalignment. A vertical take-up carriage, hanging in a festoon of belt, must be guided in its travel so that the pulley shaft remains horizontal. The belt cannot be depended upon to center itself on the pulley. Once it becomes off-center, the pulley will tip out of horizontal if not guided closely on its posts.

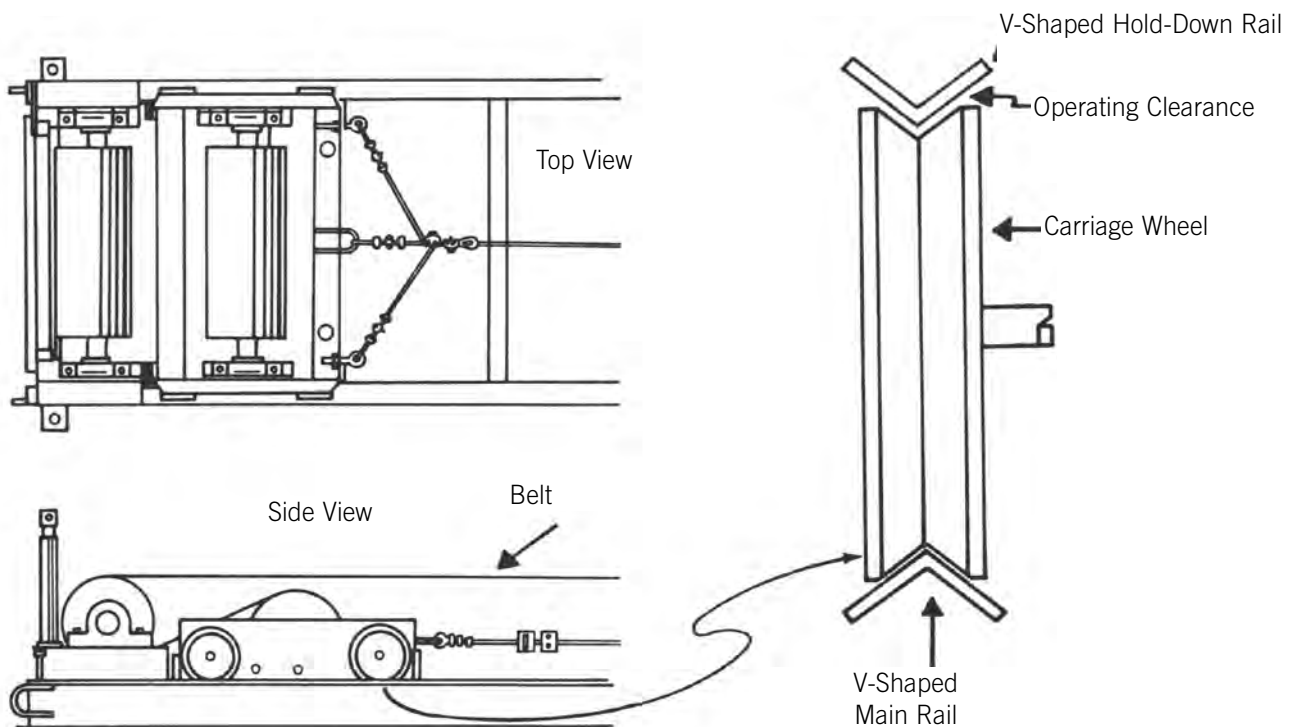
# INSTALLATION, MAINTENANCE & TROUBLESHOOTING GUIDE

## INSTALLATION

A horizontal take-up carriage (Fig. 14) is subject to misalignment due to loose track gauge, fouled rails, or even jumping off the track. V-shaped rails will hold the gauge tight and, with the apex upward, are self-cleaning. Hold-down rails or hooks extending under the flange of the track structure will prevent jumping off the track.

With the empty belt trained satisfactorily, good operation with load is usually ensured. Disturbances that appear with load are usually due to off-center loading or to accumulation of material from the load on snub pulleys and return idlers.

When equipment is known to be properly aligned, training action should be taken slowly--that is, in small steps, because the belt requires some time to respond to corrective measures. It should begin at some point preceding the location where runoff occurs, and gradually proceed forward in the direction of belt travel, until the runoff condition has been corrected. Under some conditions of operation where the conveyor is not level, is extremely short or is too wide to be affected by permissible crowning, belts with a special guide strip have been used. This V-guide strip runs loosely in grooved pulley and idler rolls. Guide strips are not recommended nor are they necessary for the long conveyors normally encountered in industrial use.



**Fig. 14**

Sample Horizontal Take-Up Carriage



## **CLEANING**

Special care must be exercised to keep the return rolls and snub pulleys clean. Buildup of material on this equipment has a destructive effect upon training, with the result being that the belt may run against the structure and damage itself. It is advisable wherever possible that return idlers be suspended far enough below the structure so that any misalignment or dirty idlers can be easily seen. Keeping the return rolls and snubs clean requires that the belt be clean when it enters the return run. Scraping is the most common method of ensuring cleanliness.

Rubber scrapers can be made by clamping rubber slabs 1/2" to 1" thick (not old belting) between two metal or wooden bars. Extend the rubber about twice its thickness beyond the bars and suspend the mechanism with a counter-weight to provide the pressure against the belt (Fig. 15). Replace the rubber when it wears down near the bars. Two or three such scrapers can be used in succession. The most common steel scraper is a series of diagonally set blades mounted on the end of a leaf spring to maintain pressure against the belt. These will scrape sticky materials that rubber scrapers may ride over (Fig. 16).

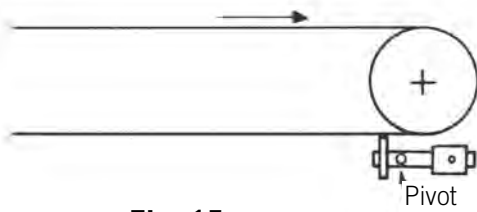
Washing the belt with a water spray before wiping with a rubber scraper will do a good cleaning job on almost any material, including iron ores and mixed concrete.

Dry materials can be cleaned off the belt with rotating bristle or rubber vane brushes, driven at fairly high surface speed, usually three to five times the belt speed (Fig. 17). They wear rapidly, require considerable maintenance and are likely to fill up solid if used with wet and sticky materials. It is preferable to clean just after the head pulley and before the snub. An exception to this is that sticky material often requires scraping on the head pulley. This is because a large part of the fine material sticks to the belt and must be scraped into the chute.

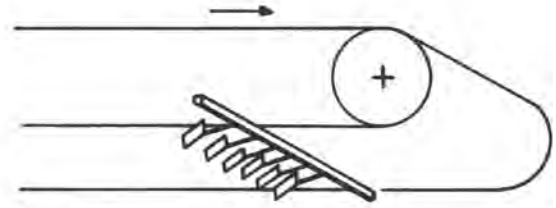
In some cases, the best possible cleaning is insufficient and steps must be taken to compensate for the effect of a dirty belt. Snub pulleys can be kept from building up by using soft rubber lagging or by scraping directly against the pulley. Diagonal grooving will distort and discharge accumulations on these pulleys. Rubber disc or spiral type return rolls prevent buildup on themselves and thus save a training problem (Figs. 18 & 19).

The only cleaning required on the pulley side is removal of material, principally lumps, which may fall or bounce onto the return run and be carried between the belt and tail pulley if not removed (Fig. 22). Rubber-faced plows immediately in front of the tail pulley are used for this purpose (Figs. 20 & 21). They are usually held against the belt by gravity and set at an angle to the direction of belt travel.

**INSTALLATION, MAINTENANCE & TROUBLESHOOTING GUIDE**  
INSTALLATION

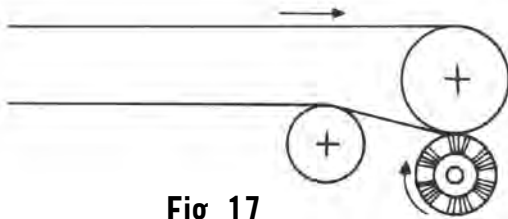


**Fig. 15**



**Fig. 16**

Articulated Blade Scraper



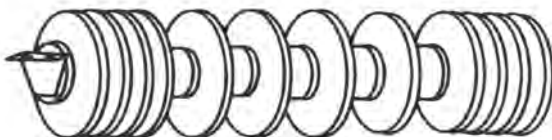
**Fig. 17**

Rotary Brush Scraper



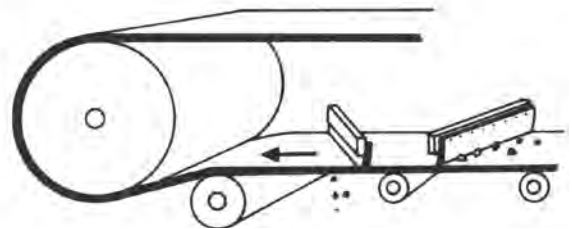
**Fig. 18**

Spiral Return Idler

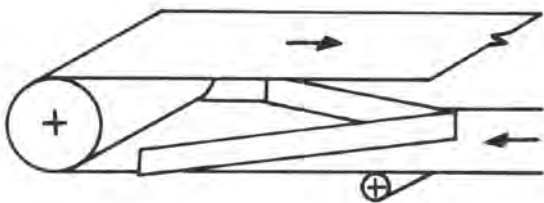


**Fig. 19**

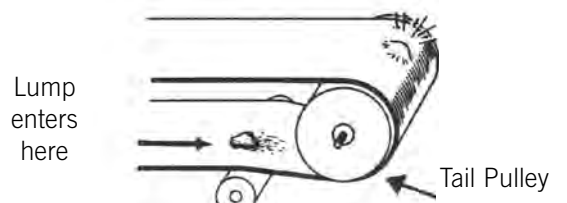
Rubber Disk Return Idler



**Fig. 20**



**Fig. 21**



**Fig. 22**

Lump enters here

Tail Pulley

## LOADING

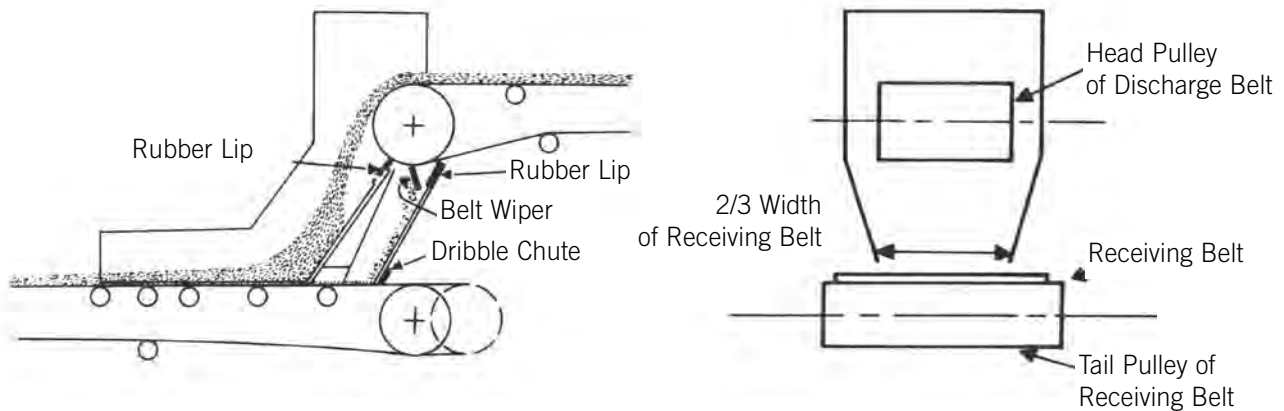
Receiving material off center will cause the belt to move sideways after loading, as the center of the load seeks the lowest point in the troughing idlers. This can be corrected by proper chute arrangement provided, of course, that the belt is centered as it enters the loading point (Fig. 23).

The loading point of any conveyor is nearly always the critical point or the life-determining point of the belt. Here, the conveyor receives its major abrasion and practically all of its impact. The “ideal condition” is to have the material pass from chute to belt, at the same speed and direction of travel as the belt and with a minimum amount of impact.

The subject of chute design and arrangement is too broad to be discussed in detail here. In lieu of such discussion, the following suggestions are offered:

The width of the receiving end of the loading chute should be great enough to accept material lying on the extreme edge of the preceding belt or feeder, and its position determined by the trajectory of the material coming into it. At no place should the chute be less than twice the size of the largest lumps, if fines are present, and 3 1/2 times the size of lumps, if uniform. The discharge width of the chute thus determined should not exceed about 2/3 of the receiving belts' width (Fig. 23).

The slope of the chute is determined by the nature of the material, its entering velocity and length of the chute. This value varies with each particular installation, but about 35 degrees has been found satisfactory for most dry industrial materials such as coal and rock.



**Fig. 23**

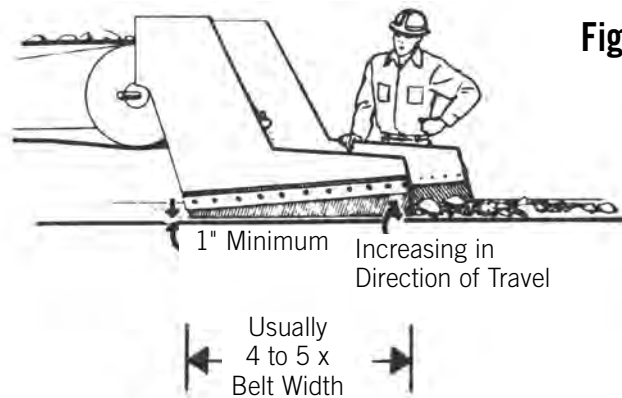
Simple Conveyor Loading Point

# INSTALLATION, MAINTENANCE & TROUBLESHOOTING GUIDE

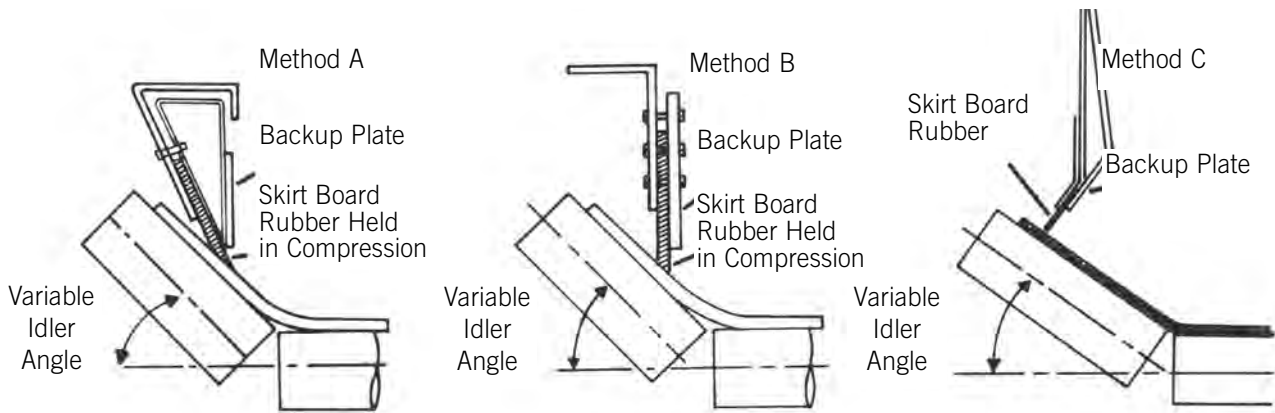
## INSTALLATION

An attempt to approach the above “ideal condition” should be made continually by adjusting the chute arrangement. Optimum loading and transferring through chutes still requires considerable experimental adjustment in the field.

Skirt boards should be used to further center and settle the load as it leaves the loading point. The steel structure of the chute and skirts never should be placed closer to the surface of the belt than 1”; this distance to be made increasing in the direction of belt travel to free any material trapped between the belt surface and the skirt (Fig. 24). Skirt boards are usually 4 or 5 times the belt width in length, but may vary considerably due to belt speed, type of material and lump size. Sample skirt board arrangements are shown in Fig. 25.



**Fig. 24**



**Fig. 25**

Sample Skirt Board Arrangements

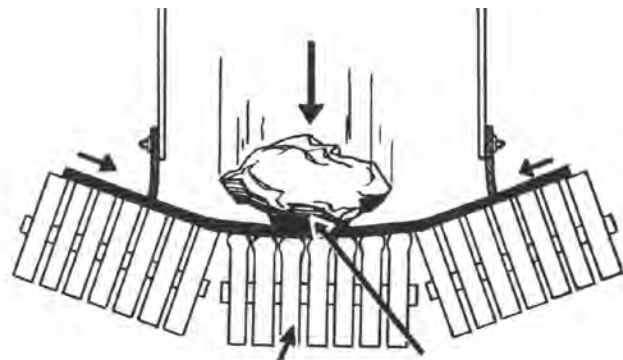
# INSTALLATION, MAINTENANCE & TROUBLESHOOTING GUIDE

## INSTALLATION

Impact of material being loaded on the belt is often the cause of severe cuts and gouges. The degree of impact can be lessened to some extent by providing a cushion in the form of rubber covered disc type or semi-pneumatic idlers, which also tend to prevent material from crowding under the skirt boards at the instant of impact (Fig. 26).

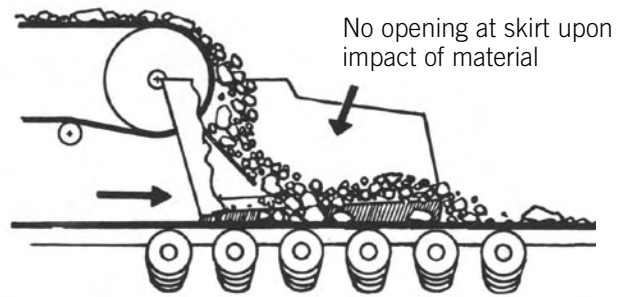
The use of a "Grizzly," a slightly fanned row of bars, at the bottom of the transfer chute reduces wear on the belt. It distributes the impact of large lumps by allowing the fines to fall onto the belt first to act as a cushion. The fan shape of the "Grizzly" in the direction of travel prevents jamming of the lumps (Fig. 27).

A "V-slot" cut in the bottom of the chute is another very satisfactory method of allowing fines to fall on the belt before the lumps and thereby reducing belt wear at this point (Fig. 28).



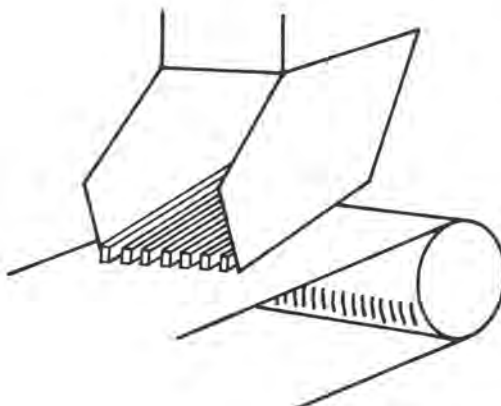
Belt cushioned by semi-pneumatic or rubber disc type idlers – preventing damage to belt

Deflection instantaneous and localized

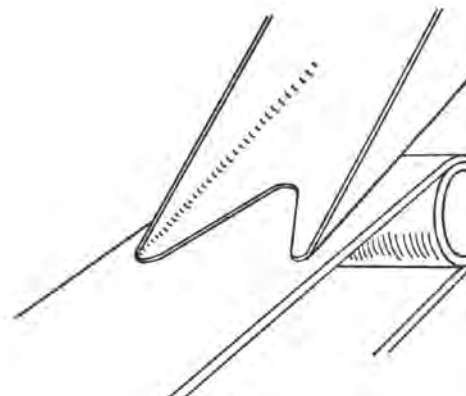


Semi-pneumatic or rubber disc type idler arrangement, placed as close together as possible

**Fig. 26**



**Fig. 27**  
Grizzly Chute

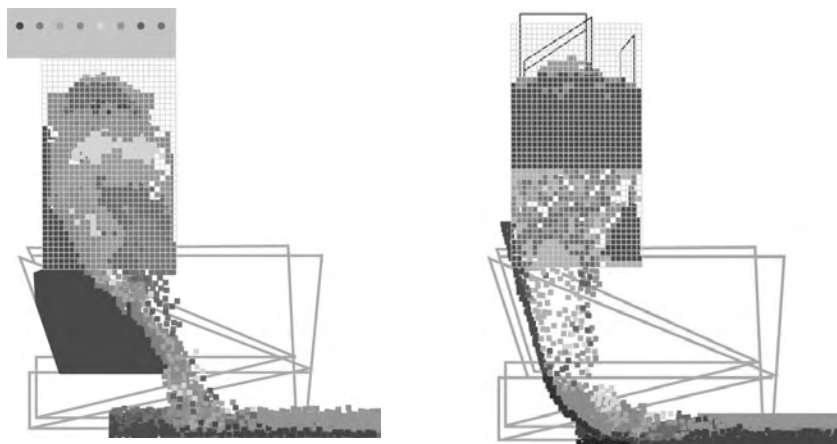


**Fig. 28**  
V-Slot Chute

## CURVED CHUTES

### Engineered loading chutes to reduce abrasion, cut/gouge and impact

Curved chutes are engineered chutes that allow the material to come in contact with the belt at a matching speed, with minimal drop height and with less turbulence. Curved chutes minimize abrasion, as well as cut/gouge and impact damage. Curved chutes may cost more than conventional chutes, but help reduce wear and cut/gouge damage tremendously and will typically pay for themselves in a short time. Curved chutes are definitely recommended for new conveyors and for existing conveyors. Special material flow modeling techniques are used to design curved chutes (Fig. 29). Typically, the chute is designed by consultant companies who have developed specialized software for studying the material flow inside the chute. With this software, they can easily compare the effectiveness of one chute design against another. The customer should go through the exercise of cost vs. return to see if a specialized curved chute design can be justified.



**Fig. 29**

Conventional vs Curved Chute

## PULLEY LAGGING

Lagging is recommended for drive pulleys for the following reasons:

1. Improved co-efficient of friction. This permits a belt to be driven by lower slack side tension and sometimes results in lower total tension.
2. Reduction of slippage due to wet conditions, if grooved lagging is used.
3. Increased life for pulley and pulley cover of belt.

Other pulleys in the system, especially those contacting the carrying side of the belt, are often lagged to prevent buildup of material. Grooving improves cleaning action on the lagging and the belt.

## TYPES OF LAGGING

**1.** Bolted lagging is usually fabric-reinforced, the fabric being necessary to give proper bolt-holding. This type has no inner or pulley cover; where no grooving is intended, 1/8" top cover is the proper minimum, but if the lagging is to be grooved, a minimum of 1/4" top cover must be used.

Bolted lagging is usually applied in two or more circumferential strips, applied under tension with the points in the different strips staggered around the pulley (On flat-faced pulleys, one strip the width of the pulley may be used).

For open-end pulleys 5/16" or 3/8" diameter flat head elevator bolts with nuts may be used. Alternate methods include slotted bolts with tapped holes or self-tapping screws for use in welded steel pulleys. It is necessary that the bolt heads be sunk below the level of the surrounding lagging to prevent damage to the belt as it passes over the pulley. This may be accomplished by counter-sinking the holes in the pulley or, where the lagging cover is greater than about 1/8", it is possible to sink the heads merely by tightening the bolts.

Ends of the strips should be bolted in a dovetail joint as shown in Fig. 30. In addition, bolts should be used in rows running across the face and around the circumference of the pulleys no further than 10" apart in either direction. Edges of all strips should be bolted down and it is recommended that all exposed fabric edges be cemented to keep out moisture.

**2.** Vulcanized lagging is a sheet of rubber, usually 1/2" thick and bonded directly to the metal. No fabric is used because no bolt-holding reinforcement is needed. It is much longer wearing, has better and more uniform adhesion to the pulley, and eliminates the hazard of serious belt damage due to a loose bolt.

This type of lagging can be applied in two different ways:

Spiral-wrap method – generally used for lower tension applications. A 4" wide strip is recommended for ease of handling (Fig. 31). The length of the strip may be calculated by the formula:

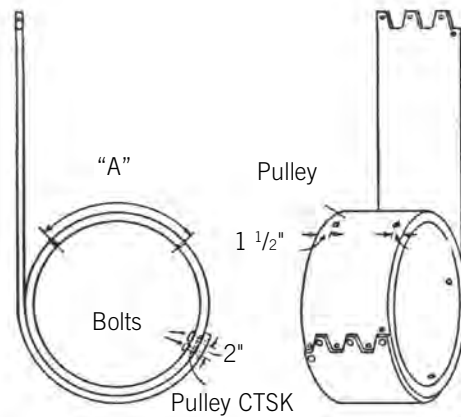
$$L = \frac{C \times W}{4} + C$$

In application by the sheet-wrap method, a beveled lateral splice is recommended (Fig. 32). The tie gum side should contact the beveled leading edge for maximum adhesion at the splice.

**3.** Grooved lagging should be used on drive pulleys if they are likely to be wet. The grooves break the film of moisture between the belt and lagging, thereby eliminating slippage. Either bolted or vulcanized lagging can be furnished with grooves. Either type can be grooved in the field with a tire-groover if there is sufficient rubber to prevent cutting into the fabric carcass or metal pulley. Herringbone grooving 3/16" deep and wide spaced 1" apart is recommended (Fig. 33).

**4.** A modified type of bolted pulley lagging is also available, featuring replaceable rubber pads that slip into metal guides bolted or welded to the pulley (Fig. 34).

**INSTALLATION, MAINTENANCE & TROUBLESHOOTING GUIDE**  
INSTALLATION



**Fig. 30**

Dovetailed Ends of Bolted Pulley Lagging

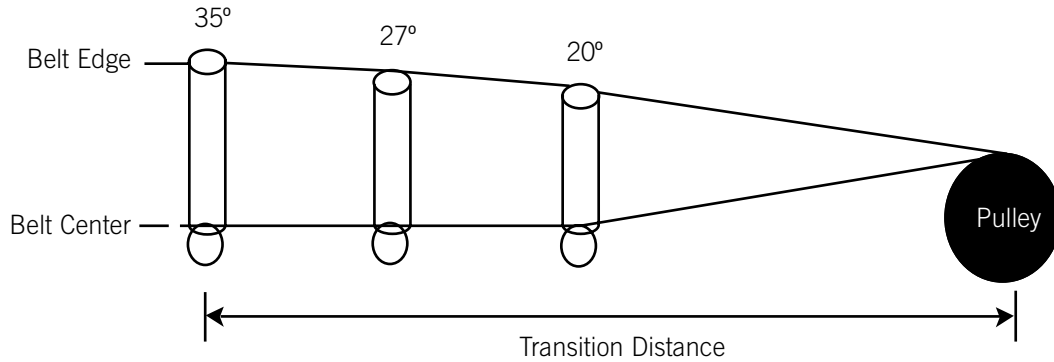
<p> <math>L = \frac{CxW}{4} + C</math> </p>	
<p><b>Fig. 31</b></p> <p>Spiral-Wrap Method of Applying Vulcanized Lagging</p>	<p><b>Fig. 32</b></p> <p>Sheet-Wrap Method of Applying Vulcanized Lagging</p>

<p><b>Fig. 33</b></p> <p>Typical Herringbone Grooved Pulley Lagging</p>	<p><b>Fig. 34</b></p> <p>Slide-Lag™ Replaceable Pad Pulley Lagging</p> <p><i>Slide-Lag™ Trademark and Patent by Holz Rubber Company, Lodi, California.</i></p>



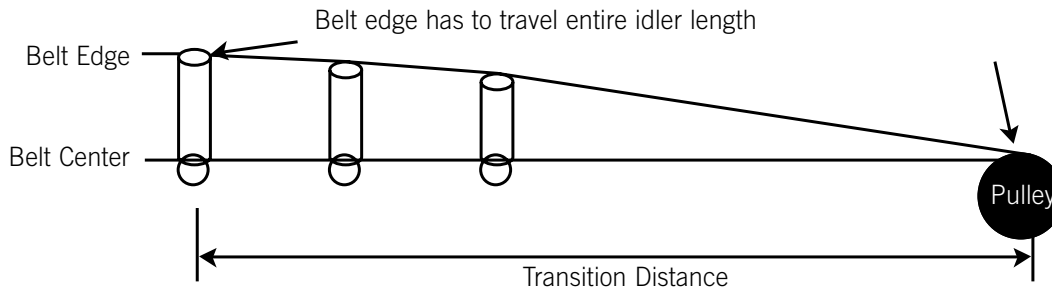
## TRANSITION DISTANCES

What is transition distance? Transition distance is the distance from the center of the head OR tail pulley to the first regular carry side idler.

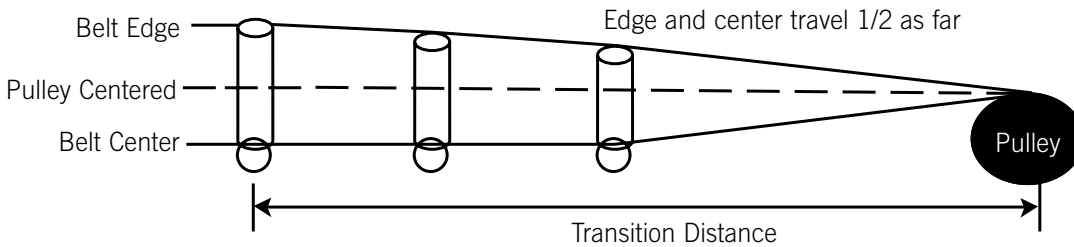


Two common types of transition distances:

### 1. Full Trough



### 2. Half Trough



Half Trough – Pulley is raised 1/2 the idler height

Why is transition distance so important? Short transitions create:

- High Edge Tensions – Max = 115% of belt rated tension
- Low Center Tension – Min = 0 piw (avoid compression)
- Premature splice failure and idler junction failures

Confirm proper transition distance through Minuteman®.

## TURNOVERS

What is a belt turnover? A belt turnover is used for keeping the dirty side up on the return side for cleaning purposes.

Goodyear Engineered Products' belt turnover recommendation is as follows:

Vertical rolls should be located near the midpoint and 45-degree rolls located at quarter locations of turnover. The midpoint rolls should be on opposite sides of the belt and offset a few inches from each other so that a component of belt tension can provide pressure against each. They should be adjustable in all directions, as their ideal ultimate position rarely can be predetermined. These rolls aid in belt training, help minimize belt-buckling tendencies and help stabilize a belt from excess flopping where winds are encountered.

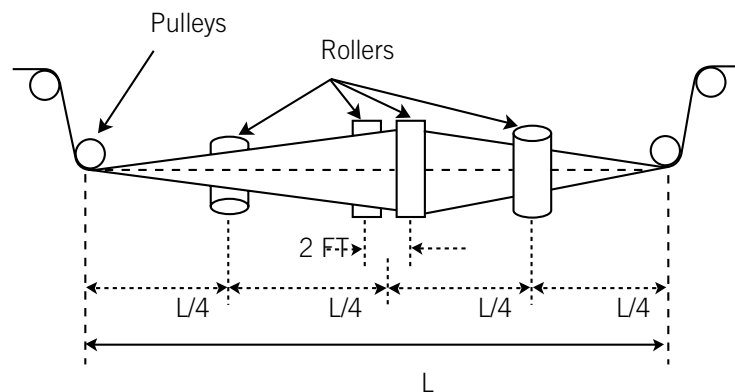
The turnover must have two terminal pulleys (inbound and outbound), as shown in the picture below. This is to insure that the belt is lying flat on the first bend pulley entering the transition and the last bend pulley leaving the transition.

Make sure the spacing between the vertical rolls is 2 ft (see picture). Each vertical roll also needs to be offset by 1" inward so that there is full belt contact on both rolls.

Each end pulley should have some adjustment in the plane of the approaching belt for training purposes.

The turnover length is determined by the belt width, type of construction and the belt tension at the turnover. Contact Goodyear Engineered Products for minimum turnover length after system analysis is performed.

Short transition distance can cause the belt to collapse in the turnover or cause excessive edge tension, which can in turn cause premature splice failure.



## **TROUBLESHOOTING**

### **PROBLEM: Conveyor runs to one side at given point on structure**

CAUSE: Buildup of material on idlers  
SOLUTIONS: Remove accumulation; improve maintenance; install scrapers or other cleaning devices

CAUSE: Sticking idlers  
SOLUTIONS: free idlers and improve maintenance and lubrication

CAUSE: Idlers or pulleys out-of-square with centerline of belt  
SOLUTIONS: Readjust idlers in affected area

CAUSE: Conveyor frame or structure crooked  
SOLUTIONS: Straighten in affected area

CAUSE: Idler stands not centered on belt  
SOLUTIONS: Readjust idlers in affected area

CAUSE: Structure not level  
SOLUTIONS: Level structure in affected area

### **PROBLEM: Particular section of belt runs to one side at all points on the conveyor.**

CAUSE: Belt not spliced/joined squarely  
SOLUTIONS: Remove affected splice and re-splice

CAUSE: Bowed belt  
SOLUTIONS: For a new belt, this condition should disappear during break-in; in rare instances, belt must be straightened or replaced; check storage and handling of the belt rolls

### **PROBLEM: Belt runs to one side for long distance or entire length of the conveyor**

CAUSE: Belt running off-center around the tail pulley and through the loading area  
SOLUTIONS: Install training idlers on the return side prior to the tail pulley

CAUSE: Off-center or poor loading  
SOLUTIONS: Adjust chute to place load on center of belt; discharge material in direction of belt travel at or near belt speed

CAUSE: Buildup of material on idlers  
SOLUTIONS: Remove accumulation; improve maintenance; install scrapers or other cleaning devices

CAUSE: Idlers or pulleys out-of-square with centerline of the belt  
SOLUTIONS: Readjust idlers in the affected area

CAUSE: Conveyor frame or structure crooked  
SOLUTIONS: Straighten in affected area

CAUSE: Idler stands not centered on belt  
SOLUTIONS: Readjust idlers in affected area

**PROBLEM: Belt runs off at the tail pulley**

CAUSE: Belt running off-center around the tail pulley and through the loading area  
SOLUTIONS: Install training idlers on the return side prior to the tail pulley

CAUSE: Material spillage and buildup  
SOLUTIONS: Improve loading and transfer conditions; install cleaning devices; improve maintenance

CAUSE: Idlers or pulleys out-of-square with centerline of the belt  
SOLUTIONS: Readjust idlers in the affected area

**PROBLEM: Belt runs off at the head pulley**

CAUSE: Pulley lagging worn  
SOLUTIONS: Replace the pulley lagging

CAUSE: Material spillage and buildup  
SOLUTIONS: Improve loading and transfer conditions; install cleaning devices; improve maintenance

CAUSE: Idlers or pulleys out-of-square with centerline of the belt  
SOLUTIONS: Readjust idlers in the affected area

CAUSE: Idler stands not centered on the belt;  
SOLUTIONS: Readjust the idlers in the affected area

**PROBLEM: Belt slip**

CAUSE: Insufficient traction between the belt and pulley;  
SOLUTIONS: Lag the drive pulley; increase the belt wrap; install belt-cleaning devices

CAUSE: Pulley lagging worn  
SOLUTIONS: Replace the pulley lagging

CAUSE: Counterweight too light  
SOLUTIONS: Add counterweight or increase the screw take-up tension to value determined from calculations

CAUSE: Material spillage and buildup  
SOLUTIONS: Improve loading and transfer conditions

CAUSE: Sticking idlers  
SOLUTIONS: Free idlers and improve maintenance and lubrication

---

# INSTALLATION, MAINTENANCE & TROUBLESHOOTING GUIDE

## TROUBLESHOOTING

### **PROBLEM: Belt slip on starting**

CAUSE: Insufficient traction between the belt and pulley;  
SOLUTIONS: Lag the drive pulley; increase the belt wrap; install belt-cleaning devices

CAUSE: Counterweight too light  
SOLUTIONS: Add counterweight or increase the screw take-up tension to value determined from calculations

CAUSE: Pulley lagging worn  
SOLUTIONS: Replace the pulley lagging

### **PROBLEM: Excessive belt stretch**

CAUSE: Improper belt installation, causing excessive belt stretch  
SOLUTIONS: Pull belt through the counterweight with tension equal to at least the empty running tension; break belt in with mechanical fasteners

CAUSE: Improper initial positioning of the counterweight in its carriage, causing apparent excessive belt stretch  
SOLUTIONS: Check the Goodyear Engineered Products' "Handbook of Belting" for the recommended initial position

CAUSE: Insufficient counterweight travel  
SOLUTIONS: Consult Goodyear Engineered Products' "Conveyor and Elevator Belt Selection Manual" for recommended minimum distances; consult the Goodyear Engineered Products' Belt Engineer

CAUSE: Tension too high  
SOLUTIONS: Increase belt speed at same tonnage; reduce tonnage, maintain same belt speed; reduce friction with better maintenance and replacement of damaged idlers; decrease tension by increasing arc of contact or go to lagged pulley; reduce the counterweight to minimum amount

CAUSE: Counterweight too heavy  
SOLUTIONS: Lighten counterweight to the value required by calculations

CAUSE: System under belted  
SOLUTIONS: Recalculate belt tensions and select proper belt

### **PROBLEM: Grooving, gouging or stripping of the top cover**

CAUSE: Skirt boards improperly adjusted or wrong material  
SOLUTIONS: Adjust the skirt board supports to a minimum of 1" between metal and belt, with gap increasing in direction of belt travel; use skirt board rubber, not old belt

CAUSE: Belt spanking down under load impact  
SOLUTIONS: Install cushion idlers

CAUSE: Material hanging up in or under the chute  
SOLUTIONS: Improve loading to reduce spillage; install baffles; widen chute

CAUSE: Impact of material on the belt  
SOLUTIONS: Reduce impact by improving the chute design; install impact idlers

---

# INSTALLATION, MAINTENANCE & TROUBLESHOOTING GUIDE

## TROUBLESHOOTING

### **PROBLEM: Excessive top cover wear, uniform around the belt**

CAUSE: Dirty, stuck, or misaligned return rolls  
SOLUTIONS: Remove accumulation; install cleaning devices; use self-cleaning return rolls; improve maintenance and lubrication

CAUSE: Cover quality too low  
SOLUTIONS: Replace with a belt of heavier-cover gauge or higher-quality rubber

CAUSE: Material spillage or buildup  
SOLUTIONS: Improve loading and transfer conditions; install cleaning devices; improve maintenance

CAUSE: Off-center loading or poor loading  
SOLUTIONS: Adjust the chute to place the load on the center of the belt; discharge material in the direction of belt travel at or near the belt speed

CAUSE: Excessive sag between idlers causing the load to work and shuffle on the belt as it passes over idlers  
SOLUTIONS: Increase tension if unnecessarily low; reduce idler spacing

### **PROBLEM: Severe pulley cover wear**

CAUSE: Sticking idlers  
SOLUTIONS: Free idlers; improve maintenance and lubrication

CAUSE: Slippage on the drive pulley  
SOLUTIONS: Increase tension through screw take-up or add counterweight; lag the drive pulley; increase arc of contact

CAUSE: Material spillage and buildup  
SOLUTIONS: Improve loading and transfer conditions; install cleaning devices; improve maintenance

CAUSE: Material trapped between the belt and pulley  
SOLUTIONS: Install plows or scraper on return run ahead of tail pulley

CAUSE: Bolts heads protruding above lagging  
SOLUTIONS: Tighten bolts; replace lagging; use vulcanized on lagging

CAUSE: Excessive forward tilt of trough rolls  
SOLUTIONS: Reduce forward tilt of idlers no more than 2 degrees from vertical

### **PROBLEM: Longitudinal grooving or cracking of bottom cover**

CAUSE: Sticking idlers  
SOLUTIONS: Free idlers and improve maintenance and lubrication

CAUSE: Slippage on the drive pulley  
SOLUTIONS: Increase tension through screw take-up or add counterweight; lag the drive pulley; increase arc of contact

---

# INSTALLATION, MAINTENANCE & TROUBLESHOOTING GUIDE

## TROUBLESHOOTING

CAUSE: Material spillage and buildup  
SOLUTIONS: Improve loading and transfer conditions; install cleaning devices; improve maintenance

CAUSE: Pulley lagging worn  
SOLUTIONS: Replace pulley lagging

### **PROBLEM: Covers harden or crack**

CAUSE: Heat or chemical damage  
SOLUTIONS: Use the belt designed for the specific condition

CAUSE: Improper storage or handling  
SOLUTIONS: Refer to Goodyear Engineered Products for proper storage and handling instructions

### **PROBLEM: Covers swells in spots or streaks**

CAUSE: Spilled oil or grease; over-lubrication of idlers  
SOLUTIONS: Improve house keeping; reduce quantity of grease used; check grease seals

### **PROBLEM: Belt breaks at or behind fasteners; fasteners pull out**

CAUSE: Fastener plates too long for pulley size  
SOLUTIONS: Replace with smaller fasteners; increase pulley size

CAUSE: Wrong type of fastener; fasteners too tight or too loose  
SOLUTIONS: Use proper fasteners and splice technique; set up schedule for fastener inspection

CAUSE: Tension too high  
SOLUTIONS: Increase belt speed, same tonnage; reduce tonnage, maintain same belt speed; reduce friction with better maintenance and replacement of damaged idlers; decrease tension by increasing arc of contact or go to lagged pulley; reduce the counterweight to minimum amount

CAUSE: Heat or chemical damage  
SOLUTIONS: Use belt designed for specific conditions

### **PROBLEM: Vulcanized splice separation**

CAUSE: Belt improperly spliced  
SOLUTIONS: Re-splice using proper method as recommended by Goodyear Engineered Products

CAUSE: Pulleys too small  
SOLUTIONS: Use larger-diameter pulleys

---

# INSTALLATION, MAINTENANCE & TROUBLESHOOTING GUIDE

## TROUBLESHOOTING

CAUSE: Tension too high  
SOLUTIONS: Increase belt speed, same tonnage; reduce tonnage, maintain same belt speed; reduce friction with better maintenance and replacement of damaged idlers; decrease tension by increasing arc of contact or go to lagged pulley; reduce the counterweight to minimum amount

CAUSE: Material trapped between belt and pulley  
SOLUTIONS: Install plows or scrapers on return run ahead of the tail pulley

CAUSE: Improper transition between troughed belt and terminal pulleys  
SOLUTIONS: Adjust transition in accordance with Goodyear Engineered Products recommendations

### **PROBLEM: Excessive edge wear, broken edges**

CAUSE: Off-center loading or poor loading  
SOLUTIONS: Adjust chute to place the load on the center of the belt; discharge material in direction of belt travel at or near belt speed

CAUSE: Material spillage and buildup  
SOLUTIONS: Improve loading and transfer conditions; install cleaning devices; improve maintenance

CAUSE: Belt hitting structure  
SOLUTIONS: Install training idlers on carry and return run

CAUSE: Bowed belt  
SOLUTIONS: For a new belt, this condition should disappear during break-in; in rare instances, the belt must be straightened or replaced; check storage and handling of belt rolls

### **PROBLEM: Transverse breaks at belt edge**

CAUSE: Belt edges folding up on structure  
SOLUTIONS: Install limit switches; provide more clearance

CAUSE: Improper transition between troughed belt and terminal pulleys  
SOLUTIONS: Adjust transitions in accordance with Goodyear Engineered Products' Handbook

CAUSE: Severe convex (hump) vertical curve  
SOLUTIONS: Decrease idler spacing in vertical curve; increase curve radius; consult Goodyear Engineered Products for assistance

### **PROBLEM: Short breaks in carcass parallel to belt edge, star breaks in carcass**

CAUSE: Impact of material on the belt  
SOLUTIONS: Reduce impact by reducing the chute design; install impact idlers

CAUSE: Material trapped between belt and pulley  
SOLUTIONS: Install plows or scrapers on return run ahead of tail pulley



**PROBLEM: Ply separation**

- CAUSE: Insufficient transverse stiffness  
SOLUTIONS: Replace with the proper belt
- CAUSE: Pulleys too small  
SOLUTIONS: Use larger-diameter pulleys
- CAUSE: Heat or chemical damage  
SOLUTIONS: Use the belt designed for specific condition

**PROBLEM: Carcass fatigue at idler junction**

- CAUSE: Improper transition between troughed belt and terminal pulleys  
SOLUTIONS: Adjust transition in accordance with Goodyear Engineered Products' "Handbook of Belting"
- CAUSE: Severe convex (hump) vertical curve  
SOLUTIONS: Decrease idler spacing in curve; increase curve radius
- CAUSE: Excessive forward tilt of troughed rolls  
SOLUTIONS: Reduce forward tilt of idlers to no more than 2 degrees from vertical
- CAUSE: Excessive gap between idler rolls  
SOLUTIONS: Replace idlers; replace with heavier belt
- CAUSE: Insufficient transverse stiffness  
SOLUTIONS: Replace with the proper belt
- CAUSE: Excess gap between idlers, causing load to work and shuffle on the belt as it passes over idlers  
SOLUTIONS: Increase tension if unnecessarily low; reduce idler spacing

**PROBLEM: Cover blisters or sandblisters**

- CAUSE: Cover cuts or very small cover punctures allow fines to work under the cover and propagate between the cover and carcass  
SOLUTIONS: Make a vulcanized spot repair or a self-curing repair
- CAUSE: Spilled oil or grease, over lubrication of idlers; improve housekeeping; reduce quantity of grease used; check grease seals  
SOLUTIONS: Decrease idler spacing in curve; increase curve radius

## FLEXSTEEL BELT REPAIRS

### 1. Repairs where there is no cable damage

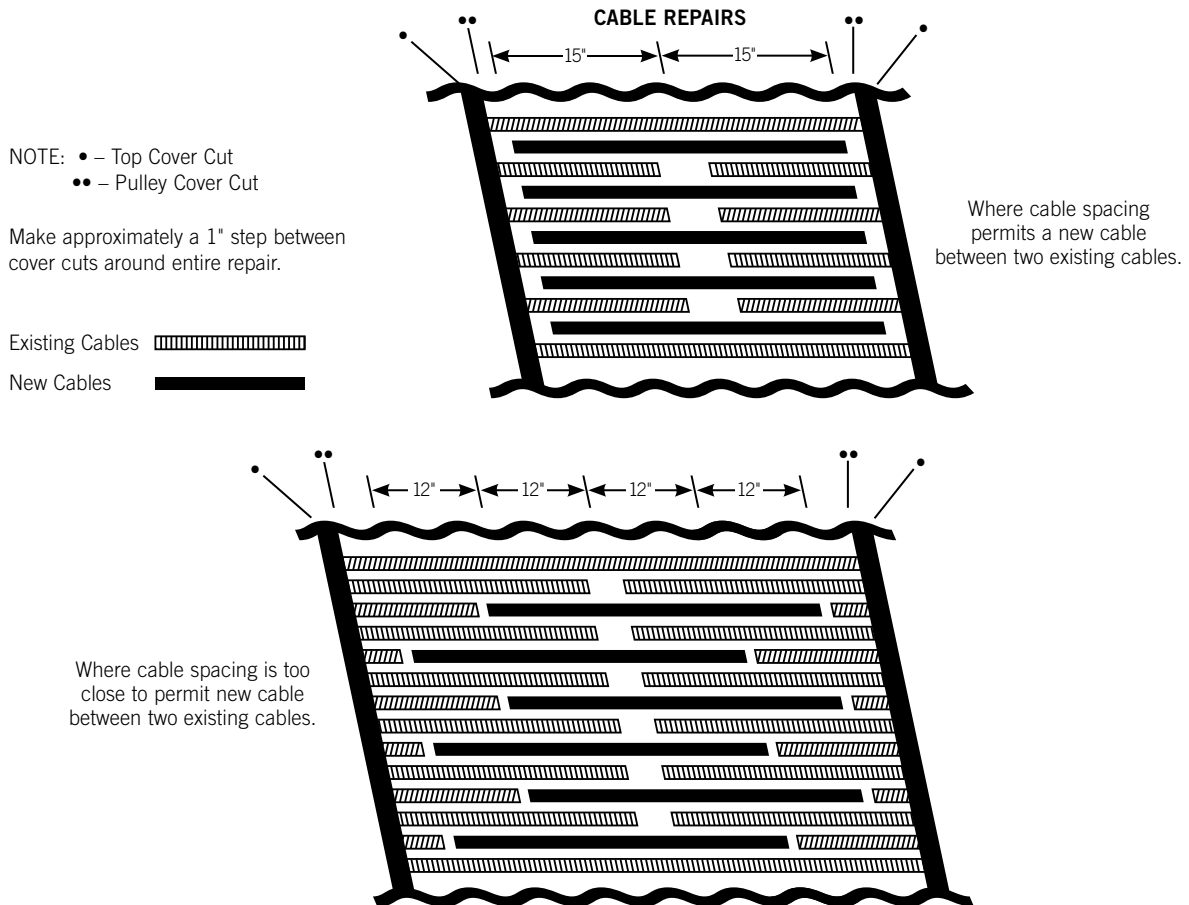
- This type of damage may be repaired in a manner more or less normal with any belt in that the damaged area is thoroughly cleaned and dried, the damaged elements (cover, plies, insulation, gum, etc.) replaced and the new elements cured.
- If cable has been exposed it is important to use the proper cable cement and cable insulation gum at that point.

### 2. Repairs involving cable damage

- If cable damage involved less than 5% of the width, simply trim the frayed cable ends and repair as per (1) above without inserting new cable.
- If damage is more extensive, sections of new cable (or pieces cut from spare belt) should be worked in. This makes a more extensive repair as the new lengths of cable should extend 15" to 24" each side of the broken area and a large vulcanizer is usually required.

The covers are removed along with insulation gum from between cables. The new cable sections are simply placed between the old broken ones extending 15" to 24" each side of the break. Cable cement, insulation gum and covers are applied and the repair is cured. The sketches below illustrate two methods used to step in lengths of new cable.

NOTE: When making cable repairs along belt edges, the tension must be removed from the belt. Even then the edge may be wavy because the new edge cables will not be carrying tension.



## TEN BEST PRACTICES IN CONVEYOR BELT VULCANIZED SPLICING

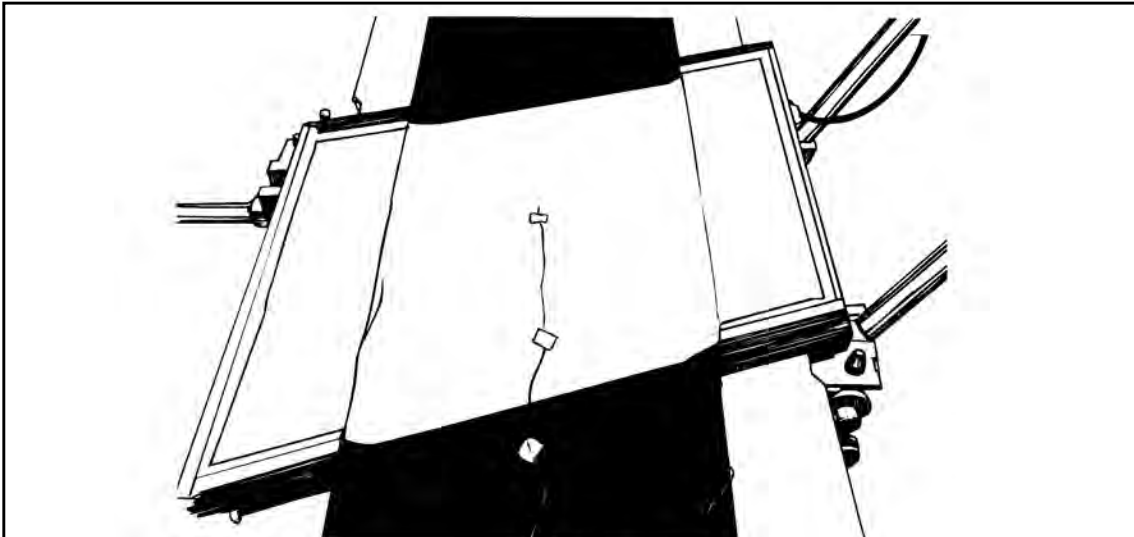
On a properly engineered, well-maintained conveyor system, a vulcanized splice done correctly will last for many years and in many cases will last the life of the belt.

Understanding and following the “TEN BEST PRACTICES IN CONVEYOR BELT SPLICING” is the best way to assure a vulcanized splice is done correctly.

Correctly performing each of the “TEN BEST PRACTICES IN CONVEYOR BELT SPLICING” when doing a fabric conveyor belt splice confirms the splicer is in CONTROL OF THE PROCESS.

### BEST PRACTICE NO. 1

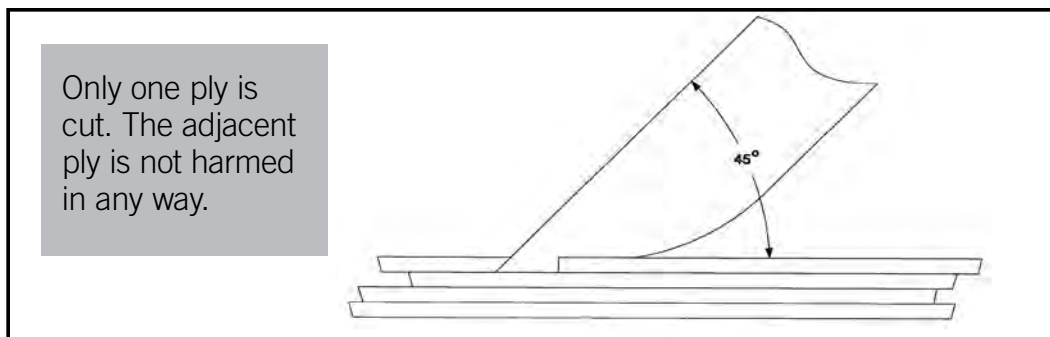
**Process control of the vulcanization curing temperature, curing time and curing pressure is vital.**



Thermocouples provide precise temperature monitoring at the platen-belt interface. A minimum of one thermocouple per platen is required. Thermostats on many vulcanizers do not indicate the actual temperature at the platen-belt interface. Without precise monitoring, the curing temperature can fluctuate drastically, resulting in a splice that is either over-cured or under-cured. Either condition will limit the life of the splice. Top splicers such as those who are members of the Goodyear Engineered Products’ Splice Network will always use thermocouples to monitor and gather cure temperature data. A record of this data can then be supplied to assure the curing process was done correctly. Top splicers will also assure that the vulcanizers’ temperature and pressure match those specified in the Goodyear Engineered Products’ “Splicing Manual of Goodyear Engineered Products Custom Specifications.”

## **BEST PRACTICE NO. 2**

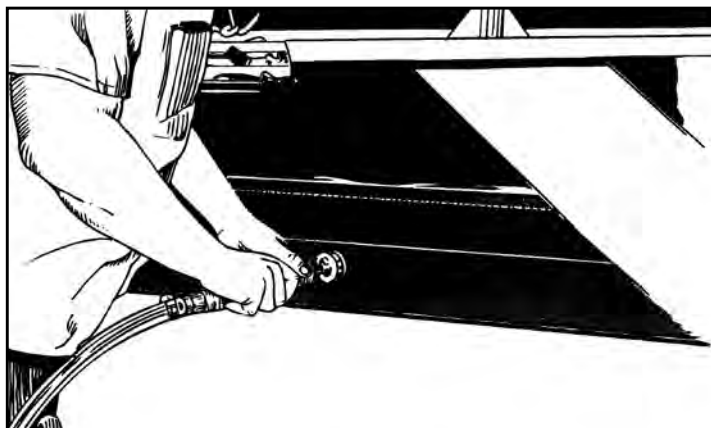
Use the proper ply knives and techniques to avoid nicking the adjacent fabric plies while stripping down the belt.



Nicking the adjacent fabric ply effectively reduces the tension rating of the belt, because the tension members (warp cords) are disabled if they are cut or nicked. Top splicers use top quality tools such as the correct single-ply knives designed specifically for this operation. Utility knives are not acceptable and must not be used for this precise operation.

## **BEST PRACTICE NO. 3**

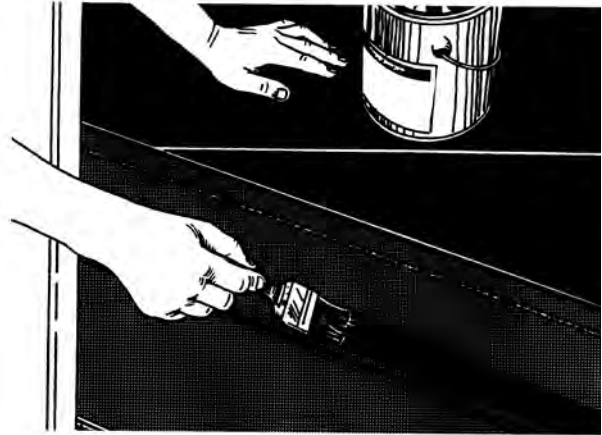
Buff the rubber surfaces only. Never directly buff the fabric.



The fabric plies of all Goodyear Engineered Products belts are coated with various “dip” coats that enhance the adhesion of the rubber to the fabric. These dip coats should not be buffed off when preparing the belt splice. Reduced ply and cover adhesion will result. If residual rubber must be buffed off after stripping down the step, it must be done carefully so that the buffer wheel does not actually touch the fabric. Severe overbuffing will reduce belt strength and integrity by damaging both warp and fill cords. The buffer wheel should not exceed 2000 RPM. A fabric cement known as “kicker” should be used to replace the dip on exposed fabric.

## **BEST PRACTICE NO. 4**

**Allow cements and solvent to dry completely before assembling the splice. When checking the cement for wetness/dryness, never use the palm of the hand or the palm side of the fingers. Oils may be transferred to the surface, which may reduce the adhesion value in this area. It is recommended to use the back side of the fingers.**



When a belt splice is assembled and cured before the cement has had sufficient time to dry, the heat from the vulcanizer will cause the solvents and carriers in the cement to vaporize and form bubbles / blisters. These bubbles / blisters are called “ply and/or cover blows.” They will prevent adhesion between the plies and covers. If the surface area of the ply or cover blow is large enough and/or numerous, the strength of the splice is severely limited.

Ply and cover blows can also occur when cements and solvents are not allowed to reach room temperature after removal from cold storage because water condensation occurred on the cold surface.

Reliable splicers will allow sufficient time for cements to dry before assembly and for cold materials to warm up. Additionally, conscientious splicers will not try to accelerate the drying process by using heat guns or hair dryers, since they can cause a skin to form on the surface of still-wet cements. Space heaters may be used to accelerate cement-drying time, as long as safety is not compromised in any way.

## **BEST PRACTICE NO. 5**

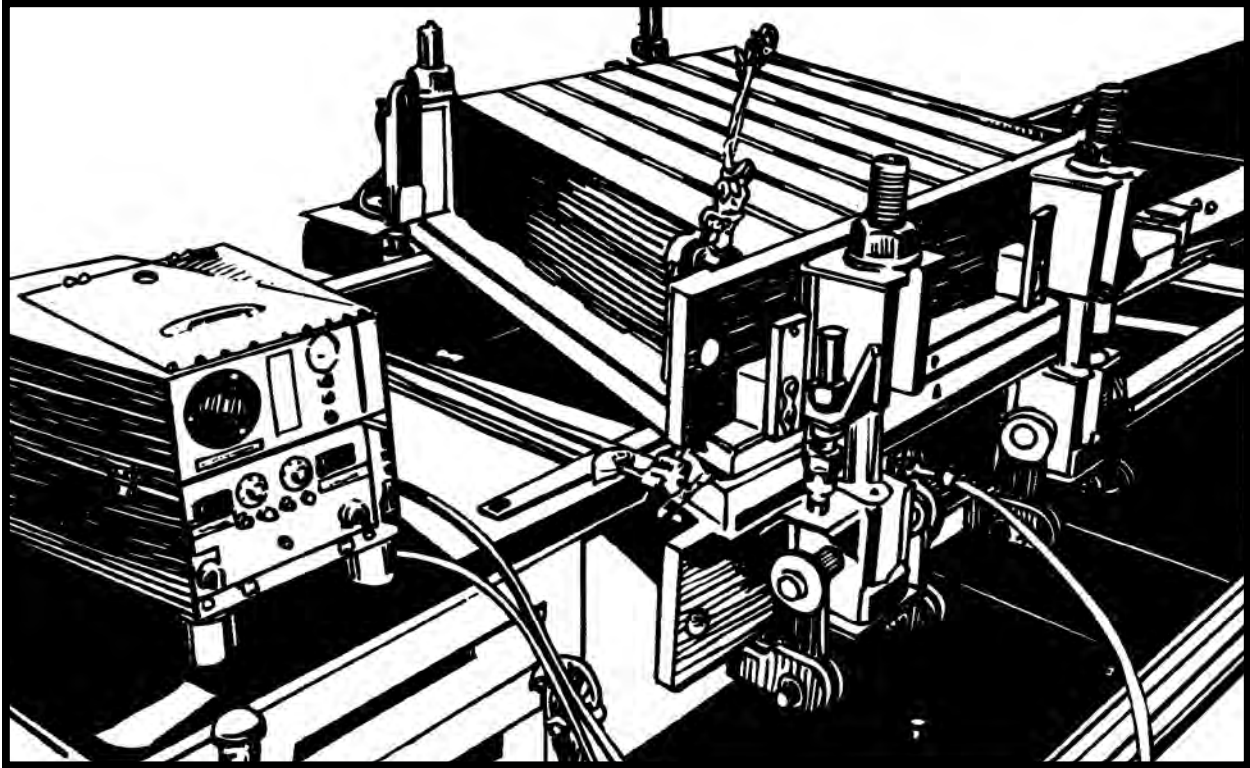
**Avoid over-prodding the fabric when lifting the plies.**

The right tools and methods will ensure that the fabric plies are not damaged when they are lifted. Prodding tools must have smooth, rounded corners. Prodding tools should be checked for possible burrs or nicks before each use.



## BEST PRACTICE NO. 6

Use the specified step, finger, and bias lengths.



When step lengths are shortened to accommodate vulcanizers that are not large enough for the job, splice strength and integrity is severely reduced. Reputable splicers will always use the step lengths specified by the “Conveyor Belt Splicing Manual” or custom specifications supplied by Goodyear Engineered Products. It is recommended to cure the entire belt splice in one heat; multiple heats can be used as long as the cover fill-in strip area is completely cured in one heat. It is also recommended that pans are used at the top and bottom platens when multiple heats are needed. The pans and edge guides must cover the entire length of the platens and extend the length of the splice.

## **BEST PRACTICE NO. 7**

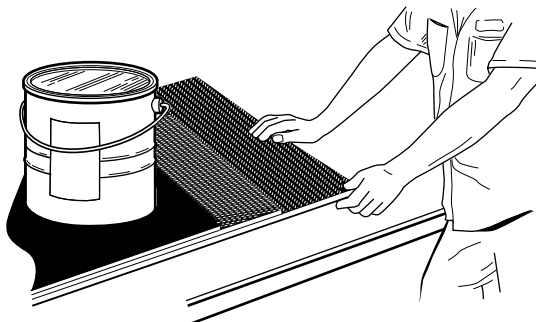
**Have a clean work area to help ensure clean assembly of the splice.**

Long experience has shown that almost anything can get inside a vulcanized splice. Goodyear Engineered Products engineers and technicians have found tools, dust, trash, sand, insects, rocks and many other types of contamination inside of splices that have failed.

For these reasons, the splicing work area must be cleaned and protected. Tents, awnings, tarps, or temporary plywood walls and ceilings should be installed, depending on the particular circumstances in which the work must be done. These measures will help avoid contamination in the splice.

## **BEST PRACTICE NO. 8**

**Never use cement or gums that are out of date.**



Goodyear Engineered Products splice materials are manufactured to the highest standards. Part of this quality control includes recording on the labels the dates the materials were manufactured. Materials that are refrigerated will have a longer shelf life than materials that are stored outside the refrigerated area. When unused materials reach the Goodyear Engineered Products recommended storage-life limit, they should then be properly disposed of in complete accordance with federal, state and local requirements. Splice materials should never be stored in sunlight or hot conditions. Never use overage splice materials. If in doubt – throw it out.

## **BEST PRACTICE NO. 9**

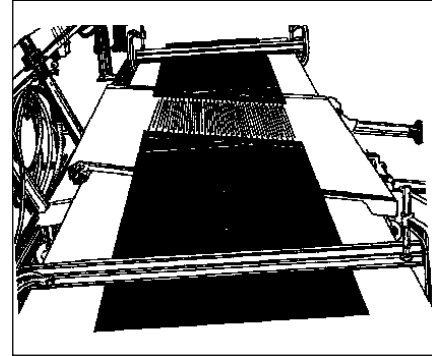
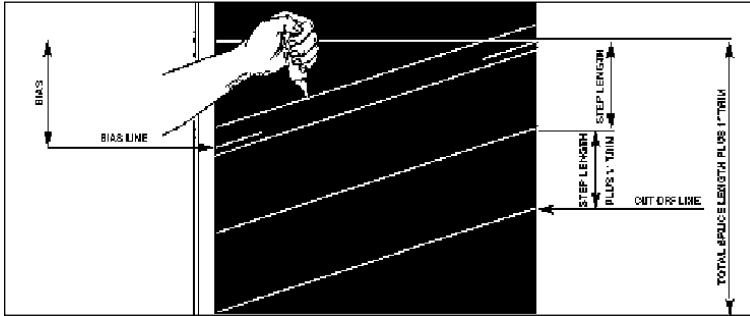
**Use only the specified splice materials for the belt being spliced.**

For best adhesion and splice life, Goodyear Engineered Products conveyor belts should be spliced with Goodyear Engineered Products splice materials. Only materials that have proven compatibility and supply the highest performance are supplied to our customers as splice materials.

Even with the use of Goodyear Engineered Products splice materials, care must be used to ensure the correct gums and cements are used. Your Goodyear Engineered Products Splice Coordinator can be consulted.

## BEST PRACTICE NO. 10

Align the splice squarely and properly.



Splices that are not aligned cause many problems. Tracking and training problems can frequently be traced back to splices that are not square. Additionally, splices that are out-of-square do not distribute the tension load evenly across the splice, and thus can cause premature splice failure. Reputable splicers go to great lengths to make certain that the belt is clamped securely and that all measurements, master lines and cuts are precise and accurate.

### Conclusion

When the “TEN BEST PRACTICES IN CONVEYOR BELT SPLICING” discussed above are incorporated into your standard operating procedures and specifications, and the conveyor system is properly engineered and well-maintained in the first place, a dependable, long splice life can be obtained.

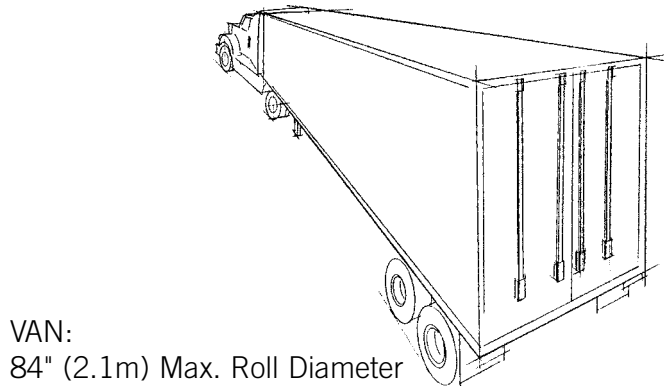
For further information regarding:

- Goodyear EP Total Belt Service™ splice materials
- Goodyear EP Conveyor Belt Splicing Manual.
- Goodyear EP Splice Network members
- Any other technical or product question

Please consult your local Goodyear EP Technical Manager (GTM).

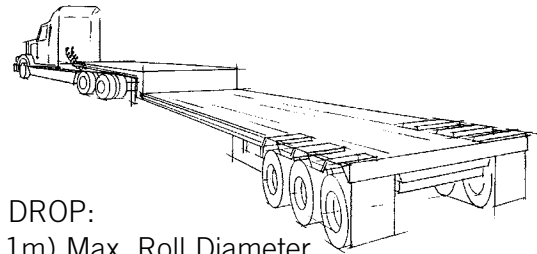


## MAXIMUM ROLL DIAMETERS FOR VARIOUS SHIPPING METHODS

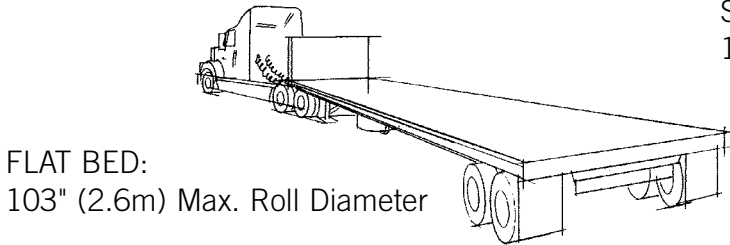


VAN:  
84" (2.1m) Max. Roll Diameter

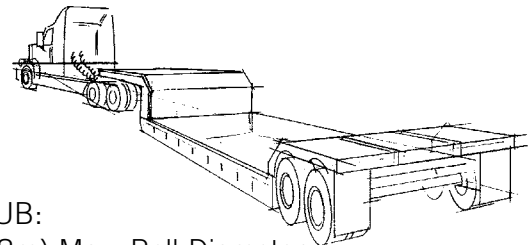
RAG TOP OR OPEN TOP:  
101" (2.5m) Max. Roll Diameter



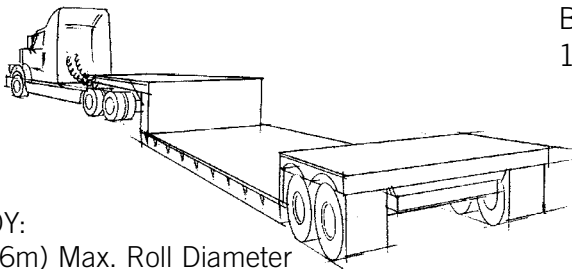
SINGLE DROP:  
122" (3.1m) Max. Roll Diameter



FLAT BED:  
103" (2.6m) Max. Roll Diameter



BATH TUB:  
152" (3.8m) Max. Roll Diameter



LOW BOY:  
144" (3.6m) Max. Roll Diameter

---

If shipment on flat bed or single drop exceeds 40,000 lbs., shipment on low boy or bath tub exceeds 36,000 lbs. or shipment exceeds listed maximum roll diameters, please contact customer service – 1-800-BELT-USA, or our Bowmanville, Ontario, Canada facility at 1-800-263-7788 for additional charges.

# INSTALLATION, MAINTENANCE & TROUBLESHOOTING GUIDE

## QUICK CHECK

### QUICK-CHECK method for approximate maximum tension (T<sub>m</sub>) used only on existing conveyors which require power when loaded.

**NOTE: Do not use for decline belts.**

Many small conveyors require more carcass for load support and impact than is required for maximum tension. For that reason, the belt selection is based primarily on load support, pulley diameter, impact and cost. However, during the investigation of such belts, it is advisable to check the possibility that maximum tension may be a factor.

In such cases, QUICK-CHECK offers a quick, simple method of **approximating** the maximum tension. If the result is low enough to show that tension is not a factor, then no further calculations are required. However, if the result indicates tension may be a factor, then more data should be gathered and maximum tension calculated using the appropriate formulas.

The appropriate maximum tension will normally be higher than that obtained through the regular formulas. To determine the approximate maximum tension using QUICK-CHECK:

#### IMPERIAL

1. Find the proper belt speed, type of take-up, and type of pulley; the corresponding number is the approximate maximum tension per motor horsepower.
2. Multiply this number (T<sub>m</sub>, approximate maximum tension per motor horsepower) by motor horsepower to obtain approximate maximum tension in pounds.
3. Divide the approximate maximum tension in pounds by the belt width to obtain the approximate required PIW.
4. If the approximate PIW is equal to or greater than the tension rating of the load support belt, then a more accurate maximum tension should be calculated. Contact your local Goodyear EP distributor for assistance.

#### METRIC

1. Find the proper belt speed, type of take-up, and type of pulley; the corresponding number is the approximate maximum tension per motor kilowatt.
2. Multiply this number (T<sub>m</sub>, approximate maximum tension per motor kilowatt) by motor kilowatts to obtain approximate maximum tension in newtons.
3. Divide the approximate maximum tension in newtons by the belt width to obtain the approximate required N/mm or kN/m.
4. If the approximate T<sub>m</sub> is equal to or greater than the tension rating of the load support belt, then a more accurate maximum tension should be calculated. Contact your local Goodyear EP distributor for assistance.

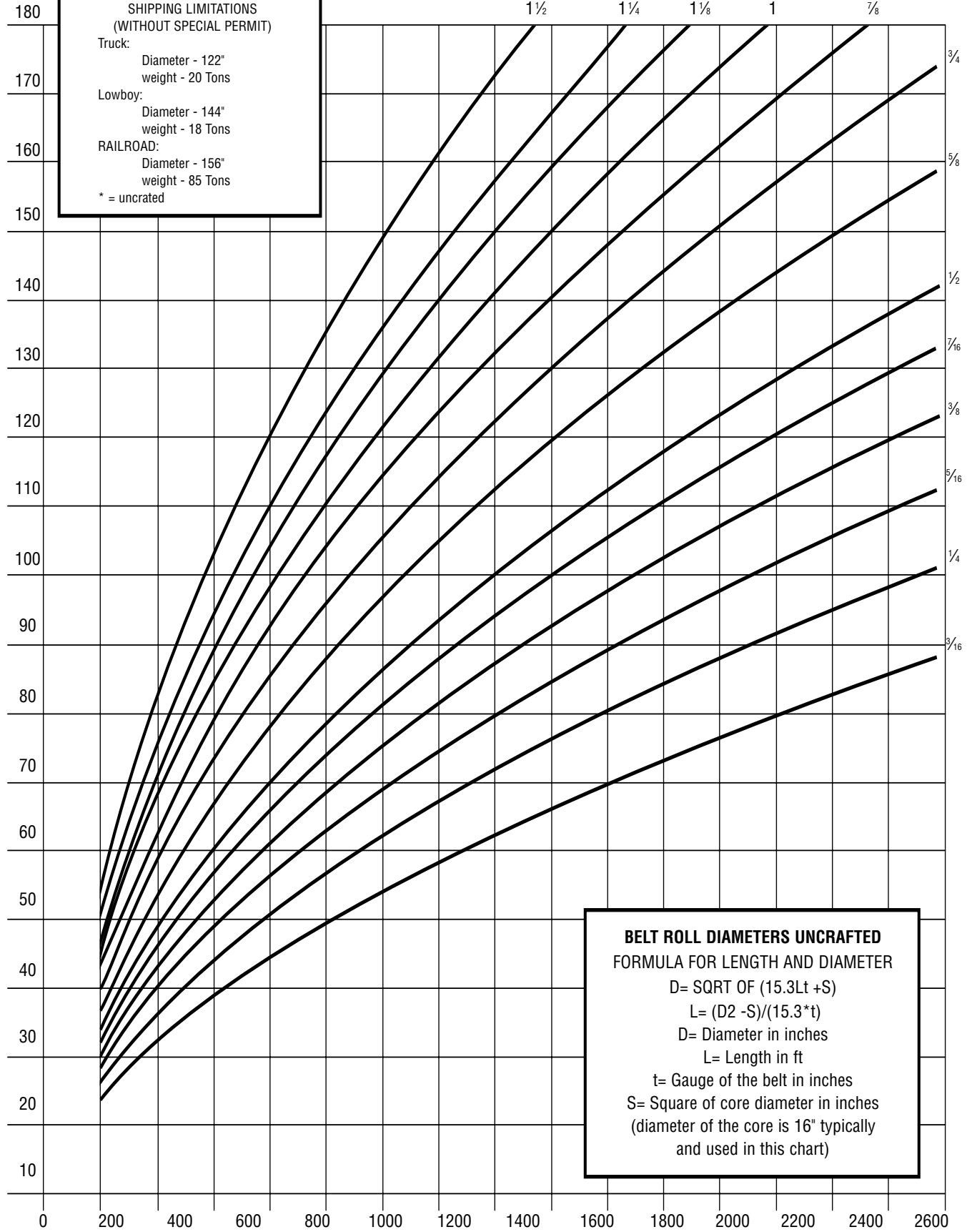
<b>IMPERIAL VALUES</b>				
<b>QUICK-CHECK METHOD FOR MAXIMUM TENSION – SINGLE PULLEY DRIVES</b>				
Belt Speed "S" Ft./Min.	APPROX. "T <sub>m</sub> "—lbs. per Motor HP (Power Requiring Conveyors only) (10% Drive Losses)			
	Counterweight Take-Up		Screw Take-Up	
	Lagged Pulley	Bare Pulley	Lagged Pulley	Bare Pulley
50	820	892	986	1070
100	410	446	493	535
150	273	297	329	356
200	206	224	248	268
250	164	179	198	224
300	136	148	164	178
350	117	127	141	153
400	102	111	123	133
450	91	99	110	119
500	83	90	100	108
550	75	81	90	97
600	69	75	83	90
650	64	69	77	83
700	59	65	72	77
750	55	60	67	72

<b>METRIC VALUES</b>				
<b>QUICK-CHECK METHOD FOR MAXIMUM TENSIONS – SINGLE PULLEY DRIVES</b>				
Belt Speed "S" Meters/Sec.	APPROX. "T <sub>m</sub> "—Newtons per motor Kw (Power Requiring Conveyors only) (10% Drive Losses)			
	Counterweight Take-Up		Screw Take-Up	
	Lagged Pulley	Bare Pulley	Lagged Pulley	Bare Pulley
0.25	4968	5400	5976	6480
0.50	2484	2700	2988	3240
0.75	1656	1800	1992	2160
1.00	1242	1350	1494	1620
1.25	994	1080	1195	1296
1.50	828	900	996	1080
1.75	710	771	854	926
2.00	641	675	747	810
2.25	552	600	664	720
2.50	497	540	598	648
2.75	452	491	543	589
3.00	414	450	498	540
3.25	382	415	460	498
3.50	355	386	427	463
3.75	331	360	398	432
4.00	310	337	374	405
4.25	292	318	352	381
4.50	276	300	332	360

# IMPERIAL BELT ROLL DIAMETERS

**FACTORY MAXIMUMS**  
 DIAMETER - 168"  
 WEIGHT - 50 TONS  
**SHIPPING LIMITATIONS**  
 (WITHOUT SPECIAL PERMIT)  
 Truck:  
 Diameter - 122"  
 weight - 20 Tons  
 Lowboy:  
 Diameter - 144"  
 weight - 18 Tons  
 RAILROAD:  
 Diameter - 156"  
 weight - 85 Tons  
 \* = uncrafted

UNCRATED BELT ROLL DIA. — INCHES



**BELT ROLL DIAMETERS UNCRATED**  
 FORMULA FOR LENGTH AND DIAMETER  
 $D = \text{SQRT OF } (15.3Lt + S)$   
 $L = (D^2 - S) / (15.3 * t)$   
 D= Diameter in inches  
 L= Length in ft  
 t= Gauge of the belt in inches  
 S= Square of core diameter in inches  
 (diameter of the core is 16" typically  
 and used in this chart)

BELT GAUGE — INCHES

BELT LENGTH — FEET

# METRIC BELT ROLL DIAMETERS

**FACTORY MAXIMUMS**  
 DIAMETER - 168"  
 WEIGHT - 50 TONS  
**SHIPPING LIMITATIONS**  
 (WITHOUT SPECIAL PERMIT)

Truck:  
 Diameter - 3.1m (122")  
 weight - 18.14 Mtons

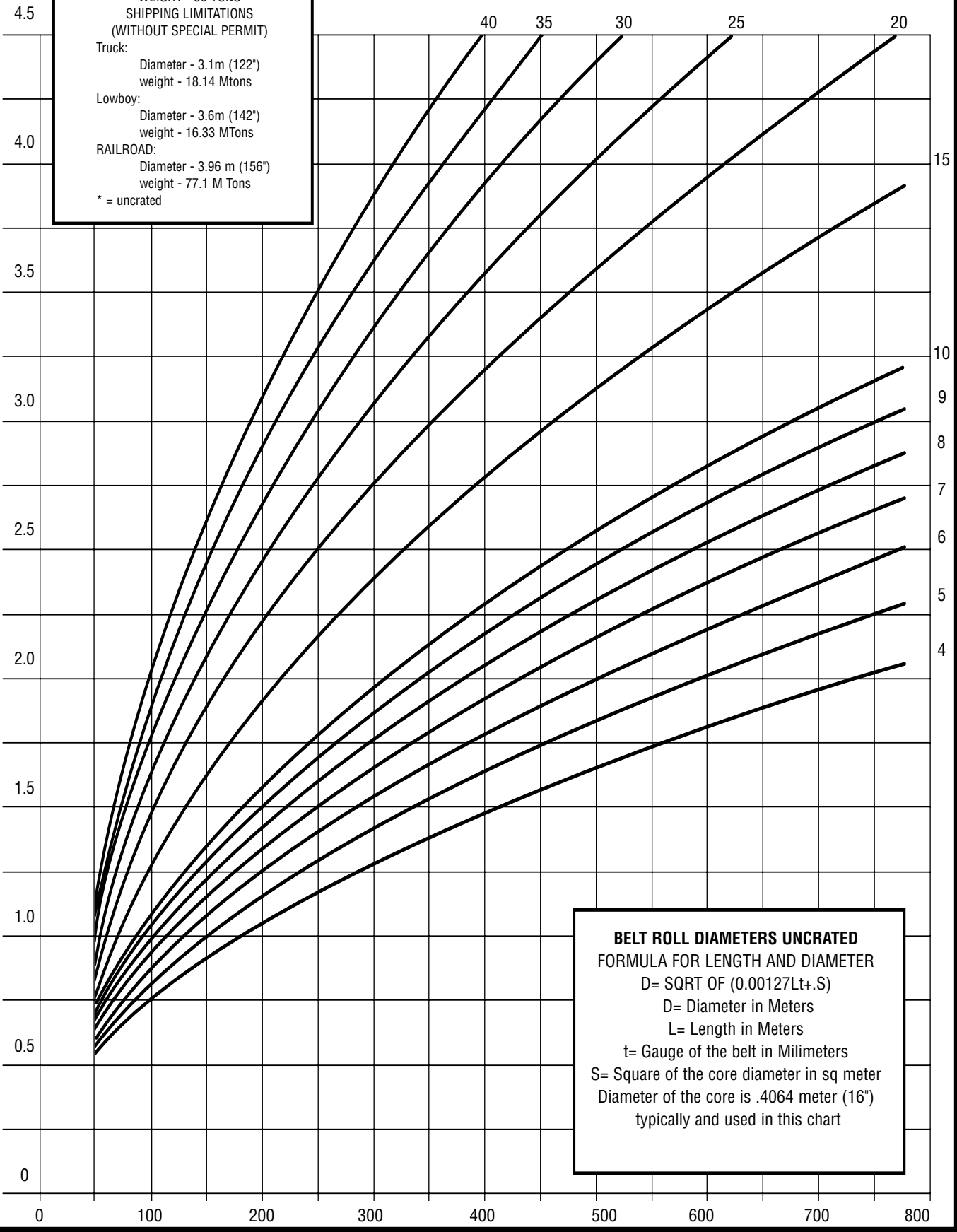
Lowboy:  
 Diameter - 3.6m (142")  
 weight - 16.33 MTons

RAILROAD:  
 Diameter - 3.96 m (156")  
 weight - 77.1 M Tons

\* = uncrated

UNCRATED BELT ROLL DIA. — METERS

BELT GAUGE — MILLIMETERS



**BELT ROLL DIAMETERS UNCRATED**  
 FORMULA FOR LENGTH AND DIAMETER  
 $D = \text{SQRT OF } (0.00127Lt + S)$   
 D= Diameter in Meters  
 L= Length in Meters  
 t= Gauge of the belt in Millimeters  
 S= Square of the core diameter in sq meter  
 Diameter of the core is .4064 meter (16")  
 typically and used in this chart

BELT LENGTH — METERS

# VEYANCE TECHNOLOGIES INC.

## Quotation Provisions

### TERMS AND CONDITIONS OF SALE

THE INFORMATION HEREIN CONTAINED CONSTITUTES A CONFIRMATION OF CUSTOMER'S ORDER OR A CONFIRMATION OF CHANGE TO CUSTOMER'S ORDER, AS APPLICABLE, (COLLECTIVELY "CONFIRMATION") AND WHICH CONFIRMATION IS EFFECTIVE UPON VEYANCE'S DISPATCH OF THIS CONFIRMATION. ANY PRIOR RECEIPT BY CUSTOMER FROM ANY OTHER SOURCE OF ALL OR PART OF THE INFORMATION HEREIN IS FOR INFORMATIONAL PURPOSES ONLY AND DOES NOT CONSTITUTE A LEGALLY BINDING CONFIRMATION. THIS CONFIRMATION IS EXPRESSLY MADE SUBJECT TO AND IS STRICTLY LIMITED TO THE TERMS AND CONDITIONS OF SALE STATED HEREIN AND ANY INCONSISTENT TERMS OR CONDITIONS APPEARING ON CUSTOMER'S ORDER ARE SPECIFICALLY OBJECTED TO AND DISCLAIMED. IN ANY COMMUNICATION WITH VEYANCE REGARDING THIS ORDER, PLEASE REFER TO VEYANCE'S DOCUMENT OR ORDER CONFIRMATION NUMBER.

1. This Confirmation and any distributor's agreement, if any, between Customer and Veyance or Veyance affiliate, together with any specifications, schedules, exhibits, riders, or other writings which may be annexed hereto or provided for hereunder and by reference made a part hereof, sets forth the complete and final agreement between Veyance and Customer in respect of the subject matter hereof, and supersedes all prior understandings, assurances, and Customer's order form, if any. THIS AGREEMENT CONTAINS THE ENTIRE UNDERSTANDING BETWEEN CUSTOMER AND VEYANCE AND NO OTHER REPRESENTATION OR INDUCEMENT, ORAL OR WRITTEN, HAS BEEN MADE WHICH IS NOT SET FORTH HEREIN. INFORMATION, ORAL OR WRITTEN, SHALL BE LEGALLY BINDING UPON VEYANCE OR SHALL BE THE BASIS FOR RELIANCE BY CUSTOMER. CUSTOMER DOES NOT RELY AND IS NOT RELYING UPON ANY ORAL OR WRITTEN STATEMENT, WARRANTY OR REPRESENTATION OF VEYANCE, ITS EMPLOYEES, AGENTS AND/OR REPRESENTATIVES NOT FULLY SET FORTH HEREIN. No amendments or modifications of or supplements to the provisions of this Confirmation will be valid and binding upon Veyance unless such amendment, modification or supplement is mutually agreed to in writing and signed by an officer of Veyance and an authorized representative of Customer. In the event of any inconsistency between these Terms and Conditions of Sale and the provisions on the other side of this document or any supplement attached hereto, the provision contained on the other side of this document or on such supplement shall control.

2. Product sold hereunder manufactured by Veyance meets agreed specifications according to established tests performed under controlled laboratory conditions and specific test requirements. These tests are not intended to reflect the performance of the product under actual conditions. Performance of the product as a component in a finished product may not necessarily meet the test requirements. Due to the number and variety of applications for which any product sold hereunder may be purchased and because Veyance has no control over (or knowledge of) the conditions under which the product may be used by others, VEYANCE DOES NOT RECOMMEND SPECIFIC APPLICATIONS OR PRODUCT DESIGNS OR ASSUME RESPONSIBILITY FOR USE RESULTS OBTAINED OR SUITABILITY FOR SPECIFIC APPLICATIONS. No statement contained herein shall be construed as a license to operate, or as a recommendation or inducement to infringe existing patents or as an endorsement of products of specific manufacturers or systems.

3. NO RELIANCE. CUSTOMER ACKNOWLEDGES THE USE OF ITS OWN KNOWLEDGE, SKILL, JUDGMENT, EXPERTISE AND EXPERIENCE IN (i) the selection of the product and/or (ii) in the selection, provision, or designation of any specification or set of specifications for a product agreed upon by Customer and Veyance; and CUSTOMER ACKNOWLEDGES THAT CUSTOMER DOES NOT RELY AND IS NOT RELYING ON ANY ORAL OR WRITTEN STATEMENTS, REPRESENTATIONS, OR SAMPLES MADE OR PRESENTED BY VEYANCE, ITS EMPLOYEES, AGENTS AND/OR REPRESENTATIVES TO CUSTOMER. CUSTOMER ACKNOWLEDGES THAT CUSTOMER DOES NOT RELY AND IS NOT RELYING ON ANY KNOWLEDGE, SKILL, JUDGMENT, EXPERTISE OR EXPERIENCE OF VEYANCE, ITS EMPLOYEES, AGENTS AND/OR REPRESENTATIVES IN CUSTOMER'S SELECTION OF THE PRODUCT OR IN CUSTOMER'S SELECTION, PROVISION OR DESIGNATION OF ANY SPECIFICATION OR SET OF SPECIFICATIONS. Without limiting the foregoing, CUSTOMER ACKNOWLEDGES THAT VEYANCE SHALL NOT BE LIABLE FOR, AND CUSTOMER ASSUMES ALL RISK OF, INACCURATE OR UNSUITABLE SPECIFICATIONS OR INFORMATION PROVIDED, SELECTED OR DESIGNATED BY CUSTOMER.

4. LIMITATION OF WARRANTY. PRODUCT NOT MANUFACTURED BY VEYANCE IS SOLD WITHOUT WARRANTY, "AS-IS" AND IS SUBJECT TO THE LIMITATION OF LIABILITY SET FORTH IN SECTION 5. SUBJECT TO THE LIMITATIONS OF SECTION 5 AND UNLESS OTHERWISE EXPRESSLY PROVIDED HEREIN, product sold hereunder that has been manufactured by Veyance, unless sold without warranty "AS-IS", is warranted to be free from defects in material and workmanship. Subject to the preceding sentence, and except as otherwise expressly provided herein, VEYANCE MAKES NO REPRESENTATION OR WARRANTY OF ANY KIND, EXPRESS OR IMPLIED, AS TO MERCHANTABILITY, FITNESS FOR A PARTICULAR PURPOSE, OR ANY OTHER MATTER WITH RESPECT TO THE PRODUCT OR ANY OTHER PRODUCT SOLD HEREUNDER, WHETHER USED ALONE OR IN COMBINATION WITH ANY OTHER MATERIAL OR PRODUCT OR IN ANY PROCESS. VEYANCE SHALL NOT BE LIABLE FOR SPECIAL, INCIDENTAL AND/OR CONSEQUENTIAL DAMAGES, EVEN IF VEYANCE HAS BEEN NOTIFIED OF THE POTENTIAL OF SUCH A LOSS OR CLAIM. OTHER THAN THOSE SPECIFICALLY SET FORTH HEREIN, THERE ARE NO WARRANTIES WHICH EXTEND BEYOND THE DESCRIPTION OF THE PRODUCTS ON THE FACE HEREOF, EITHER EXPRESS OR IMPLIED.

5. LIMITATION OF LIABILITY OF VEYANCE AND EXCLUSIVE REMEDY.

Any Veyance-manufactured product claimed to be defective in material or workmanship shall, upon Veyance's approval, be returned to Veyance as designated, at the Customer's expense. VEYANCE WILL, AS THE EXCLUSIVE REMEDY, MAKE AN ADJUSTMENT FOR PRODUCT IT FINDS TO BE DEFECTIVE IN MATERIAL OR WORKMANSHIP EITHER BY REPAIRING IT OR REPLACING IT AT AN ADJUSTMENT PRICE, OR IN LIEU THEREOF, AT VEYANCE'S OPTION, VEYANCE MAY REFUND THE PURCHASE PRICE UPON RETURN OF THE PRODUCT. Whenever a warranty for a specific product provides that no adjustment shall be made after a specified period of time, Veyance shall not be responsible under the terms of such warranty unless claim is made within such period of time. VEYANCE'S TOTAL RESPONSIBILITY AND LIABILITY FOR ANY AND ALL CLAIMS, LOSSES AND DAMAGES OF ANY KIND WHATSOEVER ARISING OUT OF ANY CAUSE WHATSOEVER (WHETHER UNDER ANY WARRANTY OR BASED IN CONTRACT, NEGLIGENCE, OTHER TORT, STRICT LIABILITY, BREACH OF WARRANTY, OTHER THEORY OR OTHERWISE) SHALL NOT EXCEED THE ORIGINAL PURCHASE PRICE OF THE PRODUCTS IN RESPECT TO WHICH SUCH CAUSE ARISES, AND IN NO EVENT SHALL VEYANCE BE LIABLE FOR SPECIAL, INCIDENTAL, CONSEQUENTIAL, EXEMPLARY, OR PUNITIVE DAMAGES RESULTING FROM ANY SUCH CAUSE. NO EMPLOYEE, AGENT AND/OR REPRESENTATIVE HAS AUTHORITY TO MAKE ANY REPRESENTATION, PROMISE OR AGREEMENT, EXCEPT AS STATED HEREIN. VEYANCE SHALL NOT BE LIABLE FOR, AND CUSTOMER ASSUMES ALL LIABILITY FOR, PERSONAL INJURY AND PROPERTY DAMAGE CONNECTED WITH THE HANDLING, TRANSPORTATION, OR FUTURE MANUFACTURE, FABRICATION, ASSEMBLY, OR PROCESSING OF THE PRODUCT.

6. Prices are subject to change without notice and such items will be billed at prices in effect at the time of shipment. Customer will be notified of any price increase and may cancel any undelivered portion of the order by written notice to Veyance provided such written notice is received by Veyance not more than 10 days after your receipt of notification of the increase. Upon such cancellation Customer shall have no liability to Veyance for the canceled portion of the order except as to product manufactured or in process, components procured by Veyance from outside sources, and special tooling and equipment procured for performance of this order.

7. All prices are subject to increase from time to time to compensate for any tax, excise or levy imposed upon the products sold, or upon the manufacture, sale, transportation, or delivery of them or whenever any tax, excise, levy law or governmental regulation has the effect, directly or indirectly, of increasing the cost of manufacture, sale or delivery. If any government action or law should have the effect of establishing a maximum price on product to be delivered, Veyance may, at its option and without liability to Customer, terminate its obligation with respect to future shipments upon thirty (30) days written notice.

8. Veyance shall not be liable or deemed in default for failure to deliver or delay in delivery due to any cause beyond its reasonable control. If unable to meet delivery schedules, Veyance will endeavor to allocate material fairly among its Customers, but reserves to itself final determination of the deliveries to be made without liability.

9. Veyance will indemnify its Customer against all claims and demands for infringement of any United States patent by the product furnished under any accepted order provided the Customer notifies Veyance of any patent infringement and upon request tenders Veyance the defense of the claim. CUSTOMERS WHO FURNISH SPECIFICATION TO VEYANCE AGREE TO HOLD VEYANCE HARMLESS AGAINST ANY CLAIMS WHICH ARISE OUT OF VEYANCE'S COMPLIANCE WITH SUCH CUSTOMER SPECIFICATIONS.

10. Title to the goods shall pass to Customer upon passage of the risk of loss; provided, however, that to the extent permitted by law, until each of the goods delivered hereunder has been paid for in full, Veyance shall retain title to the goods; however, all risk of loss and responsibility for transportation and storage, taxes and duties shall transfer in accordance with these terms of sale. Customer hereby agrees that notwithstanding any information shown in this confirmation regarding any estimated shipment, production or requested date(s) for the goods, Veyance is not obligated to produce, deliver or ship the goods by that estimated shipment, production or requested date(s). Customer hereby agrees that unless Customer notifies Veyance in writing within ninety (90) calendar days of the estimated shipment date as shown on the last dated Confirmation referencing the goods, there shall be a presumption that goods conforming to the goods ordered were received by Customer.

11. Due to the varying location of the operations of Customer and Veyance and the locations that may be involved in the performance and documentation of an order to which these Terms and Conditions of Sale are applicable, in order to settle upon and to eliminate any doubt as to the rights of the Customer and Veyance, Customer and Veyance agree that this Confirmation shall be governed by and construed in accordance with the laws of the State of Ohio, United States of America, applicable to agreements to be performed in the State of Ohio, except that for sales or orders originating and to be performed in Canada by Canadian subsidiaries or affiliates of The Veyance, Customer and Veyance agree that this Confirmation shall be governed by and construed in accordance with the laws of the Province of Ontario, Canada, applicable to agreements to be performed in Canada. Customer and Veyance exclude the application of the United Nations Convention on Contracts for the International Sale of Goods to this Confirmation and order.

